

City of Monticello, Iowa

www.ci.monticello.ia.us

Monticello City Council Meeting April 6, 2026 at 6:00 p.m.
Monticello Renaissance Center, 220 E. 1st Street, Monticello, Iowa

| | | | |
|----------------------|-----------------|---------------------------------|----------------------|
| Mayor: | Jake Ellwood | Staff: | |
| City Council: | | City Administrator: | Russell Farnum |
| At Large: | Josh Brenneman | City Clerk/Treas.: | Sally Hinrichsen |
| At Large: | Scott Brighton | Police Chief: | Britt Smith |
| At Large: | Ben Duehr | Library Director: | Faith Brehm |
| At Large: | Dave Goedken | Public Works Dir.: | Nick Kahler |
| At Large: | Candy Langerman | Water/Wastewater Sup.: | Jim Tjaden |
| At Large: | Mary Phelan | Park & Rec Director: | Jacob Oswald |
| | | Ambulance Director: | Lori Lynch |
| | | City Engineer: | Patrick Schwickerath |

- **Call to Order – 6:00 P.M.**
- Pledge of Allegiance
- Roll Call
- Agenda Addition/Agenda Approval

Open Forum: If you wish to address the City Council on subjects pertaining to today's meeting agenda please wait until that item on the agenda is reached. If you wish to address the City Council on an item not on the agenda, please approach the lectern and give your name and address for the public record before discussing your item. Individuals are normally limited to speaking for no more than three (3) minutes on a topic and the Open Forum is by rule limited to a total of twenty (20) minutes.

Consent Agenda (These are routine items and will be enacted by one motion without separate discussion unless someone requests an item removed to be considered separately.)

| | | |
|---|-------|----------|
| Approval of Council Mtg. Minutes | March | 16, 2026 |
| Approval of Council Work Session minutes | March | 23, 2026 |
| Approval of Council Work Session minutes | March | 30, 2026 |
| Approval of Payroll | March | 19, 2026 |
| Approval of Claims List | | |
| Approval of tobacco permits for Kwik Star #1763 and Fareway Stores #840 | | |
| Approval of Four Points RV Resort of Ia LLC (Jellystone Park) alcohol license | | |
| Approval of Four Points RV Resort of Ia LLC (Jellystone Park) fireworks permit for July 5, 2025 | | |
| Approval of Monticello Area Chamber of Commerce alcohol permit | | |
| Approval of Caseys General Store #1889 alcohol permit | | |

Resolutions:

1. **Resolution** Scheduling Public Hearing on the City of Monticello 2026/2027 Fiscal Year budget for April 20, 2026 at 6:00 p.m.
2. **Resolution** Approving the purchase of EMT3 9 Position Rapid Response Kits for the Monticello Ambulance Service
3. **Resolution** Approving Jones County SAFE and Healthy Youth Coalition Investment and agreement for FY '27 in the amount of \$3,000.00
4. **Resolution** Approving Maquoketa River Watershed Management Authority Investment and Agreement for FY '27 in the amount of \$3,030.00, plus five (5) water sampling locations
5. **Resolution** Approving Jones County Economic Development (JCED) Investment and agreement for FY '27 in the amount of \$15,000.00 and \$4,000 in in-kind office and internet services
6. **Resolution** Approving Monticello Firefighters of Iowa Organization Inc., planning of the Independence Day Fireworks festivities to be held on July 4, 2026 and authorizes payment in the amount of \$2,600.00 towards the fireworks
7. **Resolution** Approving Jones County JETS Transportation System investment and agreement for FY '27 in the amount of \$1,500.00
8. **Resolution** Approving Jones County Senior Dining investment and agreement for FY '27 in the amount of \$4,495.00
9. **Resolution** Approving Jones County Tourism Investment and Agreement for FY '27 in the amount of \$1,212.00, plus 4% of the Monticello Hotel/Motel tax
10. **Resolution** Appropriating funds necessary to meet the City's Obligation to Monticello Main Street Iowa Program Agreement in the amount of \$40,000.00
11. **Resolution** Approving 28E Agreement between Monticello Community Schools and City of Monticello use of School Owned Property and Facilities
12. **Resolution** Approving the wages for Monticello Aquatic Center and Park and Recreation part-time seasonal staff positions and setting wages
13. **Resolution** Approving the hiring of a Monticello Ambulance EMT/AEMT and setting wage
14. **Resolution** Adopting Wage Chart for Full Time Hourly Employees for July 1, 2026 through June 30, 2029

15. **Resolution** Adopting FY '27 Salaries and Wages for the Non-Hourly, Library, Department Heads and Permanent Part-Time Staff
16. **Resolution** Updating the salary and residency requirements, and otherwise affirm the Employment Agreement of Russell Farnum as City Administrator
17. **Resolution** Approving Plat of Survey to Parcel 2026-24 located at 17213 Hardscrabble Road
18. **Resolution** Approving Plat of Survey to Parcel 2026-25 located just North of 1503 South Main Street
19. **Resolution** Approving Plat of Survey to Parcel 2026-26 located at 1503 South Main Street
20. **Resolution** Approving Amended Tri-County Propane Site Plan (Hinz)
21. **Resolution** Approving Plat of Survey to Parcel 2026-27 located at 205 East Varvel Street

Reports / Potential Actions:

22. Mayor
23. City Engineer
24. City Administrator
25. Police Chief
26. Water/Wastewater Superintendent
27. Park and Recreation Director
28. Library Director
29. Ambulance Director
30. City Clerk
31. Public Works Director
32. Council

Adjournment: Pursuant to §21.4(2) of the Code of Iowa, the City has the right to amend this agenda up until 24 hours before the posted meeting time.

Monticello City Council meetings are recorded; by attending and choosing to participate you give your consent to be recorded. If you prefer not to be recorded, you may submit comments in writing.

The meeting will continue to be broadcast on Mediacom (Local Access Channel) and will be accessible via Zoom via the following link.

City of Monticello is inviting you to a scheduled Zoom meeting.

Topic: April 6, 2026 Council Meeting

Time: Apr 6, 2026 06:00 PM Central Time (US and Canada)

Join Zoom Meeting

<https://us02web.zoom.us/j/89647551475>

Meeting ID: 896 4755 1475

One tap mobile

+16469313860,,89647551475# US

+13017158592,,89647551475# US (Washington DC)

Join instructions

<https://us02web.zoom.us/join/89647551475?signature=d-wJcOd-yjH5Am-h33tv2KZmVEww5ZVuyGVeWqPjVxY>

“This employer is an equal opportunity provider & employer”

Regular Council Meeting
March 16, 2026, 6:00 P.M.
Community Media Center

Mayor Jake Ellwood called the meeting to order. Council present were: Candy Langerman, Mary Phelan, Ben Duehr and Scott Brighton. Also present were City Administrator Russell Farnum, City Clerk Sally Hinrichsen, Water /Wastewater Superintendent Jim Tjaden, Library Director Faith Brehm, Parks and Rec Director Jacob Oswald, Ambulance Director Lori Lynch and City Engineer Colton Ingles. Council members Josh Brenneman and Dave Goedken were absent. The public was invited to attend the meeting in person, or to participate in the meeting electronically via “Zoom Meetings” or “Facebook” and were encouraged to communicate from the chat or message.

Brighton moved to approve the agenda. Phelan seconded, roll call was unanimous.

Brighton moved to approve the consent agenda, Langerman seconded. Roll call was unanimous.

Langerman moved to approve Resolution #2026-26 Approving Pay Request #7 to Roger Stephen, Re: Stephen Addition Trunk Sewer Project and for partial payment of retainage to Roger Stephen, Re: Stephen Addition Trunk Sewer Project in the amount of \$70,930.67. Phelan seconded. Roll call was unanimous.

Langerman moved to approve Resolution #2026-27 Approving the hiring of a Monticello Ambulance On-Call Driver and setting wage. Brighton seconded. Roll call was unanimous.

Phelan moved to approve Resolution #2026-28 To Acknowledge the hiring of Monticello Library seasonal employee and setting wage. Langerman seconded. Roll call was unanimous.

Langerman moved to approve Resolution #2026-29 Approving Pay Request #22 to Bill Bruce Builders, Inc., Re: Wastewater Treatment Plant Improvement Project in the amount of \$845,993.31. Brighton seconded. Roll call was unanimous. When asked Farnum advised the completion date for this project is June 2027.

Oswald reported Trees Forever no longer requires a Tree Board to get funding or grants. With the Park Board creating Pillars, it will be incorporated into one of them and looking to increase the size of the Park Board. Brighton moved to approve Resolution #2026-30 Proposing the discontinuation of the “City Tree Board” and Scheduling Public Hearing pursuant to Iowa Code Section 392.7. Phelan seconded. Roll call was unanimous.

Langerman moved to approve Resolution #2026-31 approving the Purchase of a Hustler zero turn mower for Cemetery from Kromminga Motors. Brighton seconded. Roll call was unanimous.

Regular Council Meeting
March 16, 2026

Farnum advised the next several easements were for the Sixth Street Ditch Project. Ingles advised they were in contact with DNR and Corp of Engineers to get the permits again for this project. Being the permits were previously approved; it should be quicker to get them re-approved. They are looking at bidding the project in May and contract approval in June. Brighton moved to approve Resolution #2026-32 To Accept and Approve a Temporary Construction Easement with Scott Wilcox for the 6th Street Ditch Restoration Project. Langerman seconded. Roll call was unanimous.

Langerman moved to approve Resolution #2026-33 To Accept and Approve a Permanent Drainage Easement and Maintenance Agreement with Scott Wilcox for the 6th Street Ditch Restoration Project. Phelan seconded. Roll call was unanimous.

Phelan moved to approve Resolution #2026-34 To Accept and Approve a Temporary Construction Easement with Ashley Archambault for the 6th Street Ditch Restoration Project. Brighton seconded. Roll call was unanimous.

Phelan moved to approve Resolution #2026-35 To Accept and Approve a Permanent Drainage Easement and Maintenance Agreement with Ashley Archambault for the 6th Street Ditch Restoration Project. Duehr seconded. Roll call was unanimous.

Brighton moved to approve Resolution #2026-36 To Accept and Approve a Temporary Construction Easement with Autumn Wersinger for the 6th Street Ditch Restoration Project. Langerman seconded. Roll call was unanimous.

Phelan moved to approve Resolution #2026-37 To Accept and Approve a Permanent Drainage Easement and Maintenance Agreement with Autumn Wersinger for the 6th Street Ditch Restoration Project. Duehr seconded. Roll call was unanimous.

Langerman moved to approve Resolution #2026-38 To Accept and Approve a Temporary Construction Easement with Keith E. and Janice K. Tackett for the 6th Street Ditch Restoration Project. Phelan seconded. Roll call was unanimous.

Brighton moved to approve Resolution #2026-39 To Accept and Approve a Permanent Drainage Easement and Maintenance Agreement with Keith E. and Janice K. Tackett for the 6th Street Ditch Restoration Project. Duehr seconded. Roll call was unanimous.

Langerman moved to approve Resolution #2026-40 To Accept and Approve a Temporary Construction Easement with Morgan Eggiman for the 6th Street Ditch Restoration Project. Phelan seconded. Roll call was unanimous.

Phelan moved to approve Resolution #2026-41 To Accept and Approve a Permanent Drainage Easement and Maintenance Agreement with Morgan Eggiman for the 6th Street Ditch Restoration Project. Duehr seconded. Roll call was unanimous.

Brighton moved to approve Resolution #2026-42 To Accept and Approve a Temporary Construction Easement with Scott L. and Patricia Chally for the 6th Street Ditch Restoration Project. Langerman seconded. Roll call was unanimous.

Regular Council Meeting
March 16, 2026

Phelan moved to approve Resolution #2026-43 To Accept and Approve a Permanent Drainage Easement and Maintenance Agreement with Scott L. and Patricia Chally for the 6th Street Ditch Restoration Project. Duehr seconded. Roll call was unanimous.

Ellwood reported he served on the Eastern Iowa Regional Housing Authority Board and Farnum has agreed to replace him as Monticello's representative. Brighton moved to approve Resolution #2026-44 Appointing Commissioners To The Eastern Iowa Regional Housing Authority From The City Of Monticello, Iowa. Duehr seconded. Roll call was unanimous.

Brighton reported the Cemetery Board approved his proposed project to install all weather flags with the names for Veterans buried in Oakwood Cemetery, at no cost to the City. They would no longer be placing the plaques with the flags. They would put the flags up about April and leave them up through Veteran's Day. Phelan moved to approve the proposed project to install all weather flags with the names for Veterans buried in Oakwood Cemetery, seconded by Langerman. Roll call was unanimous.

Farnum reported Council member Goedken proposes to straighten, re-enforce and clean-up the fence at Oakwood Cemetery. The fence would remain in place and not a complete restoration. Barb Himes, 138 El Camino Real, stated at a previous Council meeting when the fence was discussed, all but two of the neighbors were present. The neighbors have always maintained the fence, which has been there for over 100 years. They have never asked for help or expected the help for the fence. Cemetery Board member Mary Melchert, 1 Spring Farm Lane, stated she was never informed if the fence was on the property line or not. Farnum stated the fence is fully on City property by 6 inches to a foot. Melchert stated the reason she voted against the proposed project was that it was 100 years old. She appreciates what Goedken is doing, but feels it is a Band-Aid approach to keep it together. Brighton moved to approve the Cemetery Fence repairs, as was approved by the Cemetery Board. Langerman seconded. Roll call was unanimous.

Farnum reported March 25th is the State-wide tornado drill at 10 AM. Farnum has been working on the insurance renewal. Farnum stated America 250 is this year and he is looking to decorate City Hall to commemorate the event. He continues to work on the wage scales and evaluations.

Farnum reported Public Works has been moving snow from the recent storm. They had the street sweeper out prior to the storm. Yard Waste pickup will begin on April 2nd.

Tjaden reported they had a sewer trunk line that was plugged with tree roots and Pirc-Tobin replaced about 40' of the trunk, which only comes from Merrinole Addition.

Oswald and Brehm reported on various activities for their respective departments.

Lynch advised a fulltime EMT is stepping down to parttime, so will be looking for a fulltime EMT.

Hinrichsen reported the annual audit for FY 2025 will be released tomorrow.

Regular Council Meeting
March 16, 2026

Phelan reported Park Board discussed the many programs and activities happening. Tree Board will be incorporated into the Park Board. Phelan reported the Library Board worked on updating the job descriptions.

Brighton reported the Cemetery Board discussed the fence, flags and mower, that was on the agenda tonight.

Brighton moved to go into Executive Session to discuss the purchase or sale of particular real estate only where premature disclosure could be reasonably expected to increase the price the governmental body would have to pay for that property or reduce the price the governmental body would receive for that property. The minutes and the audio recording of a session closed under this paragraph shall be available for public examination when the transaction discussed is completed. Phelan seconded the motion. Roll call was unanimous.

Brighton moved to open the open session, Langerman seconded. Roll call was unanimous. Duehr moved to direct staff to proceed as was discussed, Langerman seconded. Roll call was unanimous.

Brighton moved to go into Executive Session to evaluate the professional competency of an individual whose appointment, hiring, performance, or discharge is being considered when necessary to prevent needless and irreparable injury to that individual's reputation and that individual requests a closed session. Langerman seconded. Roll call was unanimous.

Phelan moved to open the open session, Brighton seconded. Roll call was unanimous. No action was taken.

Brighton moved to adjourn at 7:30 P.M.

Jake Ellwood, Mayor

Sally Hinrichsen, City Clerk/Treasurer

Special Council Work Session
March 23, 2026, 6:00 P.M.
Community Media Center

Mayor Jake Ellwood called the meeting to order. Council present were: Josh Brenneman, Candy Langerman, Scott Brighton, Ben Duehr and Mary Phelan. Also, present were City Administrator Russell Farnum, City Clerk Sally Hinrichsen, Library Director Faith Brehm and Ambulance Director Lori Lynch. Council member Dave Goedken was absent.

Brighton moved to approve the agenda, Brenneman seconded. Roll call was unanimous.

Director of Jones County Tourism Association Kaileen Weaver gave a presentation on Jones County Tourism and requested funding for fiscal year 2027. Monticello Main Street President Quinn Behrends, Director Brian Wolken and Board Member Deb Bowman gave a presentation and requested funding for fiscal year 2027.

Council discussed staff wages and salaries for fiscal year 2027. Farnum reviewed a proposed 3-year agreement for wages for staff. Farnum reviewed some other options and questions from the last work session, related to wages and benefits. No action was taken.

Langerman moved to adjourn at 7:14 P.M.

Jake Ellwood, Mayor

Sally Hinrichsen, City Clerk/Treasurer

Special Council Work Session
March 30, 2026, 6:00 P.M.
Community Media Center

Mayor Jake Ellwood called the meeting to order. Council present were: Candy Langerman, Scott Brighton, Ben Duehr, Mary Phelan and Dave Goedken. Also, present were City Administrator Russell Farnum, City Clerk Sally Hinrichsen, Library Director Faith Brehm and Ambulance Director Lori Lynch. Council member Josh Brenneman arrived shortly after meeting started.

Phelan moved to approve the agenda, Goedken seconded. Roll call was unanimous. Council member Josh Brenneman arrived.

Director of Jones County Economic Development Derek Lumsden gave a presentation on Jones County Economic Development and requested funding for fiscal year 2027. Watershed Coordinator Erin Erickson gave a presentation on the Maquoketa River Watershed Management Authority and requested funding for fiscal year 2027. SAFE Coalition Project Coordinator Jennifer Husmann gave a presentation on the Jones County SAFE Coalition and requested funding for fiscal year 2027.

Council discussed staff wages and salaries for fiscal year 2027. Farnum reviewed a proposed salaries for staff and some hourly staff. No action was taken.

Brighton moved to adjourn at 6:59 P.M.

Jake Ellwood, Mayor

Sally Hinrichsen, City Clerk/Treasurer

PAYROLL - APRIL 2, 2026

| DEPARTMENT | GROSS PAY | OT PAY | COMP HRS. ACCRUED | COMP TOTAL | NET PAY |
|------------------------|----------------------------|-----------------|----------------------|---------------|---------------------|
| AMBULANCE | March 16 - 29, 2026 | | | | |
| Chris Bell | \$ 528.15 | \$ - | 0.00 | 0.00 | \$ 454.28 |
| Jamie Coleman | 2,328.80 | - | 0.00 | 0.00 | 1,863.94 |
| Jordan Fullerton | 189.22 | - | 0.00 | 0.00 | 162.76 |
| Quinn Hansen | 955.74 | - | 0.00 | 0.00 | 779.45 |
| Mason Hanson | 1,346.34 | - | 0.00 | 0.00 | 1,026.66 |
| Sonya Johnson | 679.37 | - | 0.00 | 0.00 | 584.36 |
| Jayna Koffron | 871.41 | - | 0.00 | 0.00 | 749.54 |
| Lori Lynch | 3,457.51 | - | 0.00 | 0.00 | 2,348.51 |
| Coletta Matson | 2,328.80 | - | 0.00 | 20.25 | 1,659.02 |
| Chloe Mogensen | 756.86 | - | 0.00 | 0.00 | 519.92 |
| Cory Reyner | 3,969.06 | - | 0.00 | 0.00 | 3,032.30 |
| Shirlee Scott | 2,328.80 | - | 0.00 | 0.00 | 1,761.31 |
| Reggie Welter | 836.71 | - | 0.00 | 0.00 | 692.46 |
| Cora Wheeler | 827.37 | - | 0.00 | 0.00 | 685.64 |
| TOTAL AMBULANCE | \$ 21,404.14 | \$ - | 0.00 | 20.25 | \$ 16,320.15 |
| CEMETERY | March 16 - 29, 2026 | | | | |
| Dan McDonald | \$ 2,261.39 | \$ 51.79 | 0.00 | 0.00 | \$ 1,704.82 |
| TOTAL CEMETERY | \$ 2,261.39 | \$ 51.79 | 0.00 | 0.00 | \$ 1,704.82 |
| CITY HALL | March 16 - 29, 2026 | | | | |
| Cheryl Clark | \$ 2,432.13 | \$ 33.73 | 3.00 | 61.50 | \$ 1,721.36 |
| Russ Farnum | 3,711.54 | - | 0.00 | 0.00 | 2,549.40 |
| Sally Hinrichsen | 3,326.38 | - | 0.00 | 0.00 | 2,254.17 |
| Nanci Tuel | 2,282.40 | - | 0.00 | 0.00 | 1,528.55 |
| TOTAL CITY HALL | \$ 11,752.45 | \$ 33.73 | 3.00 | 61.50 | \$ 8,053.48 |
| FIRE | | | | | |
| Drew Haag | \$ 125.00 | \$ - | 0.00 | 0.00 | \$ 115.44 |
| Nick Kahler | 166.67 | - | 0.00 | 0.00 | 143.36 |
| Billy Norton | 208.33 | - | 0.00 | 0.00 | 179.19 |
| Tiler Streets | 125.00 | - | 0.00 | 0.00 | 115.44 |
| TOTAL FIRE | \$ 625.00 | \$ - | 0.00 | 0.00 | \$ 553.43 |
| LIBRARY | March 16 - 29, 2026 | | | | |
| Faith Brehm | \$ 1,914.40 | \$ - | 0.00 | 0.00 | \$ 1,466.93 |
| Molli Hunter | 1,436.00 | - | 0.00 | 0.00 | 1,162.35 |
| Penny Schmit | 1,724.80 | - | 0.00 | 0.00 | 1,167.63 |
| TOTAL LIBRARY | \$ 5,075.20 | \$ - | 0.00 | 0.00 | \$ 3,796.91 |
| MBC | March 16 - 29, 2026 | | | | |
| Milo Breitbach | \$ 1,750.00 | \$ - | 0.00 | 0.00 | \$ 1,349.78 |
| Kara Burrack | 1,344.00 | - | 0.00 | 0.00 | 1,156.64 |
| Jacob Oswald | 2,662.88 | - | 0.00 | 0.00 | 2,018.29 |
| TOTAL MBC | \$ 5,756.88 | \$ - | 0.00 | 0.00 | \$ 4,524.71 |
| POLICE | March 16 - 29, 2026 | | | | |
| Erik Honda | \$ 2,932.80 | \$ - | 0.00 | 0.00 | \$ 2,203.64 |
| Jordan Koos | 3,258.36 | - | 0.00 | 38.00 | 2,245.90 |

PAYROLL - APRIL 2, 2026

| DEPARTMENT | GROSS PAY | OT PAY | COMP HRS. ACCRUED | COMP TOTAL | NET PAY |
|---------------------------|----------------------------|------------------|----------------------|---------------|---------------------|
| Cole Millard | 2,879.52 | - | 0.00 | 0.00 | 1,931.42 |
| Johnny Norwood | 2,879.52 | - | 0.00 | 0.00 | 1,685.50 |
| Keanan Shannon | 3,157.06 | - | 27.00 | 58.50 | 2,396.88 |
| Britt Smith | 3,732.72 | - | 0.00 | 0.00 | 2,825.83 |
| Madonna Staner | 1,925.60 | - | 0.00 | 0.00 | 1,442.25 |
| Brian Tate | 3,625.29 | 31.35 | 0.00 | 0.00 | 2,369.95 |
| TOTAL POLICE | \$ 24,390.87 | \$ 31.35 | 27.00 | 96.50 | \$ 17,101.37 |
| ROAD USE | March 16 - 29, 2026 | | | | |
| Zeb Bowser | \$ 2,169.60 | \$ - | 0.00 | 28.25 | \$ 1,588.52 |
| Jacob Gravel | 2,169.60 | - | 0.00 | 12.00 | 1,642.07 |
| Nick Kahler | 2,687.50 | - | 0.00 | 0.00 | 1,980.67 |
| Jasper Scott | 2,169.60 | - | 0.00 | 0.00 | 1,634.92 |
| TOTAL ROAD USE | \$ 9,196.30 | \$ - | 0.00 | 40.25 | \$ 6,846.18 |
| SEWER | March 14 - 27, 2026 | | | | |
| Jim Tjaden | \$ 3,071.44 | \$ - | 0.00 | 0.00 | \$ 2,144.81 |
| TOTAL SEWER | \$ 3,071.44 | \$ - | 0.00 | 0.00 | \$ 2,144.81 |
| WATER | March 14 - 27, 2026 | | | | |
| Scott Hagen | \$ 2,389.60 | \$ - | 6.00 | 106.50 | \$ 1,908.37 |
| Josh Willms | 2,229.60 | - | 12.00 | 115.00 | 1,526.21 |
| TOTAL WATER | \$ 4,619.20 | \$ - | 18.00 | 221.50 | \$ 3,434.58 |
| TOTAL - ALL DEPTS. | \$ 88,152.87 | \$ 116.87 | 48.00 | 440.00 | \$ 64,480.44 |

Report Criteria:
[Report].Due Date = 04/07/2026

| Name | Description | Invoice Amount |
|---|-------------------------------|----------------|
| ERIK HONDA | PD OFFICER TRAVEL/TRAINING | 72.52 |
| JORDAN KOOS | PD OFFICERS TRAVEL/TRAINING | 79.62 |
| LASER TECH USA INC. | PD BUILDING SUPPLIES | 17.99 |
| ALL SEASONS AUTO BODY INC | PD VEHICLE OPERATING | 1,423.46 |
| JOHN DEERE FINANCIAL | PD VEHICLE OPERATING | 16.98 |
| INSURANCE ASSOCIATES INC. | POLICE PROPERTY INSURANCE | 25,931.74 |
| LYNCH DALLAS P.C. | PD ATTORNEY FEES | 1,020.70 |
| LYNCH DALLAS P.C. | PD ATTORNEY FEES | 567.50 |
| TAC10, INC. | PD TAC10 MAINTENANCE | 11,991.10 |
| KIESLER'S POLICE SUPPLY INC. | PD MINOR EQUIPMENT | 299.06 |
| Total 001-110: <i>Police</i> | | 41,420.67 |
| ALLIANT ENERGY-IES | E 1ST STREETLIGHTS | 4,801.11 |
| Total 001-230: <i>Streetlights</i> | | 4,801.11 |
| INSURANCE ASSOCIATES INC. | POOL PROPERTY INSURANCE | 8,377.71 |
| JONES CO ENVIRONMENTAL SERVICE | POOL FOOD SERVICE LICENSE | 150.00 |
| Total 001-440: <i>Pool</i> | | 8,527.71 |
| JOHN DEERE FINANCIAL | CEMETERY MAINT SUPPLIES | 25.99 |
| SYCAMORE MEDIA CORP | CEMETERY ADVERTISING | 179.60 |
| INSURANCE ASSOCIATES INC. | CEMETERY PROPERTY INSURANCE | 1,765.14 |
| ZACHARY ADAM BOWSER | CEMETERY STUMP GRINDING | 425.00 |
| Total 001-450: <i>Cemetery</i> | | 2,395.73 |
| INSURANCE ASSOCIATES INC. | SOLDEIRS MEMORIAL PROPERTY IN | 4,327.53 |
| Total 001-498: <i>Soldiers Memorial</i> | | 4,327.53 |
| MOLLI JENN HUNTER | JANITORIAL SERVICES | 262.50 |
| Total 001-620: <i>Administration</i> | | 262.50 |
| PFM FINANCIAL ADVISORS LLC | ADMIN PRO FEES | 1,000.00 |
| SNYDER & ASSOCIATES INC | ENGINEERING FEES | 1,403.40 |
| Total 001-640: <i>Engineer</i> | | 2,403.40 |
| LYNCH DALLAS P.C. | ATTORNEY FEES | 120.00 |
| LYNCH DALLAS P.C. | ATTORNEY FEES | 310.00 |
| Total 001-641: <i>Attorney</i> | | 430.00 |
| JOHN DEERE FINANCIAL | ADMIN FURNACE REPAIR/MAINT | 34.88 |
| JOHN DEERE FINANCIAL | CH DEHUMIDIFIER | 249.99 |
| SYCAMORE MEDIA CORP | ADMIN PUBLICATIONS | 610.04 |
| INSURANCE ASSOCIATES INC. | ADMIN PROPERTY INSURANCE | 35,563.08 |
| INSURANCE ASSOCIATES INC. | ADMIN PROPERTY ASSURANCE | 29.00- |
| ROTO-ROOTER | CH NUISANCE ABATEMENTS | 286.00 |

| Name | Description | Invoice Amount |
|--------------------------------------|--------------------------------|----------------|
| LIMESTONE BLUFFS R C & D | MAQUOKETA RIVER WATERSHED | 3,300.00 |
| LASER TECH USA INC. | CH OFFICE SUPPLIES | 69.98 |
| Total 001-650: <i>Administration</i> | | 40,084.97 |
| MOLLI JENN HUNTER | JANITORIAL SERVICES | 210.00 |
| JOHN DEERE FINANCIAL | MBC GROUNDS SUPPLIES | 14.97 |
| JOHN DEERE FINANCIAL | MBC GROUNDS SUPPLIES | 27.98 |
| LASER TECH USA INC. | MBC BUILDING SUPPLIES | 327.39 |
| JOHN DEERE FINANCIAL | MBC EQUIP REPAIR/MAINT | 1.65 |
| INSURANCE ASSOCIATES INC. | PARK PROPERTY INSURANCE | 20,901.90 |
| KENDRA OSWALD | MBC SOCCER SHIRTS | 1,764.00 |
| JONES CO ENVIRONMENTAL SERVICE | JOHNSON PARK FOOD SERVICE LIC | 150.00 |
| JONES CO ENVIRONMENTAL SERVICE | MBC FOOD SERVICE LICENSE | 150.00 |
| LASER TECH USA INC. | MBC OFFICE SUPPLIES | 114.44 |
| Total 005-430: <i>MBC</i> | | 23,662.33 |
| KEANAN SHANNON | PD CANINE TRAVEL/TRAINING | 540.25 |
| KEANAN SHANNON | PD CANINE TRAVEL/TRAINING | 421.41 |
| TREE TOWN KENNELS LLC | PD CANINE TRAINING & HANDLER'S | 10,000.00 |
| KEANAN SHANNON | PD CANINE SUPPLIES | 40.48 |
| Total 009-110: <i>Police Canine</i> | | 11,002.14 |
| JONES CO ENVIRONMENTAL SERVICE | SHANNON FIELD FOOD SERVICE LI | 150.00 |
| Total 012-430: <i>Tournament</i> | | 150.00 |
| JOHN DEERE FINANCIAL | FIRE BLDG REPAIR/MAINT | 2.49 |
| JONES COUNTY SOLID WASTE | FIRE BLDG REPAIR/MAINT | 38.50 |
| JOHN DEERE FINANCIAL | FIRE EQUIP REPAIR/MAINT | 113.97 |
| JOHN DEERE FINANCIAL | FIRE EQUIP REPAIR/MAINT | 26.99 |
| LAPORTE MOTOR SUPPLY | FIRE EQUIP REPAIR/MAINT | 139.55 |
| LAPORTE MOTOR SUPPLY | FIRE EQUIP REPAIR/MAINT | 20.99 |
| MES SERVICE COMPANY LLC | FIRE EQUIP REPAIR/MAINT | 63.94 |
| INSURANCE ASSOCIATES INC. | FIRE PROPERTY INSURANCE | 15,392.62 |
| MERCY PHYSICIAN ASSOCIATES | FIRE PHYSICAL - GREEN | 384.00 |
| MERCY PHYSICIAN ASSOCIATES | FIRE PHYSICAL - JA SNYDER | 384.00 |
| MERCY PHYSICIAN ASSOCIATES | FIRE PHYSICAL - MILES | 384.00 |
| MERCY PHYSICIAN ASSOCIATES | FIRE PHYSICAL - BOWSER | 384.00 |
| DINGES PARTNERS GROUP LLC | FIRE MINOR EQUIPMENT | 1,459.64 |
| MES SERVICE COMPANY LLC | FIRE MINOR EQUIPMENT | 146.95 |
| Total 015-150: <i>Fire</i> | | 18,941.64 |
| KIECK'S CAREER APPAREL | AMB UNIFORMS | 769.50 |
| JOHN DEERE FINANCIAL | AMB BUILDING SUPPLIES | 12.99 |
| JOHN DEERE FINANCIAL | AMB BUILDING SUPPLIES | 39.98 |
| JOHN DEERE FINANCIAL | AMB BUILDING SUPPLIES | 20.97 |
| JOHN DEERE FINANCIAL | AMB VEHICLE OPERATING | 19.98 |
| INSURANCE ASSOCIATES INC. | AMBULANCE PROPERTY INSURANC | 11,652.21 |
| LYNCH DALLAS P.C. | AMB ATTORNEY FEES | 100.00 |
| LASER TECH USA INC. | AMB BUILDING SUPPLIES | 18.00 |
| PHYSICIAN'S CLAIM COMPANY | AMB BILLING FEES | 75.00 |
| BOUND TREE MEDICAL LLC | AMB MEDICAL SUPPLIES | 88.25 |
| ZOLL MEDICAL CORPORATION | AMB MEDICAL SUPPLIES | 214.00 |

| Name | Description | Invoice Amount |
|---|-------------------------------|----------------|
| Total 016-160: <i>Ambulance</i> | | 13,010.88 |
| FAREWAY STORES #840-1 | LIB IMP PROGRAMS/PROMOTIONS | 16.37 |
| FAREWAY STORES #840-1 | LIB IMP PROGRAMS/PROMOTIONS | 26.35 |
| Total 030-410: <i>Library Improvement</i> | | 42.72 |
| MOLLI JENN HUNTER | JANITORIAL SERVICES | 280.00 |
| CULLIGAN TOTAL WATER - | LIB BUILDING SUPPLIES | 27.96 |
| JOHN DEERE FINANCIAL | LIB BUILDING SUPPLIES | 55.94 |
| JOHN DEERE FINANCIAL | LIB BUILDING SUPPLIES | 11.00- |
| JOHN DEERE FINANCIAL | LIB BUILDING SUPPLIES | 5.50 |
| INSURANCE ASSOCIATES INC. | LIBRARY PROPERTY INSURANCE | 11,074.94 |
| SYSTEMS TECHNOLOGY GROUP INC | LIB DATA PROGRESSING | 495.00 |
| MICRO MARKETING LLC | LIB BOOKS | 85.70 |
| MICRO MARKETING LLC | LIB AUDIO RECORDINGS | 81.88 |
| MICRO MARKETING LLC | LIB AUDIO RECORDINGS | 94.78 |
| Total 041-410: <i>Library</i> | | 12,190.70 |
| DUBUQUELAND DOOR CO. | AIRPORT BLDG REPAIR/MAINT | 378.53 |
| INSURANCE ASSOCIATES INC. | AIRPORT PROPERTY INSURANCE | 12,166.05 |
| MONTICELLO AVIATION INC | AIRPORT MANAGER | 2,750.00 |
| INSURANCE ASSOCIATES INC. | AIRPORT RENTAL PROPERTY INSUR | 1,071.65 |
| Total 046-280: <i>Airport</i> | | 16,366.23 |
| BRIAN CROWLEY | RU EQUIP REPAIR/MAINT | 45.00 |
| BRIAN CROWLEY | RU EQUIP REPAIR/MAINT | 36.00 |
| JOHN DEERE FINANCIAL | RU EQUIP REPAIR/MAINT | .41 |
| JOHN DEERE FINANCIAL | RU EQUIP REPAIR/MAINT | 6.99 |
| JOHN DEERE FINANCIAL | RU EQUIP REPAIR/MAINT | 11.49 |
| JOHN DEERE FINANCIAL | RU EQUIP REPAIR/MAINT | 91.88 |
| JOHN DEERE FINANCIAL | RU EQUIP REPAIR/MAINT | 14.48 |
| JOHN DEERE FINANCIAL | RU EQUIP REPAIR/MAINT | .75 |
| JOHN DEERE FINANCIAL | RU EQUIP REPAIR/MAINT | .55 |
| JOHN DEERE FINANCIAL | RU EQUIP REPAIR/MAINT | 238.56 |
| JOHN DEERE FINANCIAL | RU EQUIP REPAIR/MAINT | 14.48- |
| K&S MACHINING AND METAL | RU EQUIP REPAIR/MAINT | 45.97 |
| KIMBALL MIDWEST | RU EQUIP REPAIR/MAINT | 104.65 |
| LAPORTE MOTOR SUPPLY | RU EQUIP REPAIR/MAINT | 171.74 |
| LAPORTE MOTOR SUPPLY | RU EQUIP REPAIR/MAINT | 91.54 |
| LAPORTE MOTOR SUPPLY | RU EQUIP REPAIR/MAINT | 15.71 |
| SADLER POWER TRAIN INC | RU EQUIP REPAIR/MAINT | 31.84 |
| TRUCK CENTER HOLDINGS INC | RU EQUIP REPAIR/MAINT | 19.39 |
| TRUCK CENTER HOLDINGS INC | RU EQUIP REPAIR/MAINT | 39.38 |
| ALLIANT ENERGY-IES | 22059 HWY 38 | 386.77 |
| INSURANCE ASSOCIATES INC. | ROAD USE PROPERTY INSURANCE | 14,353.73 |
| JOHN DEERE FINANCIAL | RU SUPPLIES | 3.49 |
| JOHN DEERE FINANCIAL | RU SUPPLIES | 65.94 |
| JOHN DEERE FINANCIAL | RU SUPPLIES | 5.99 |
| JOHN DEERE FINANCIAL | RU SUPPLIES | 6.87 |
| JOHN DEERE FINANCIAL | RU SUPPLIES | 97.99 |
| LAPORTE MOTOR SUPPLY | RU SUPPLIES | 28.44 |
| JOHN DEERE FINANCIAL | RU STREET MAINTENANCE SUPPLIE | 38.00 |
| JOHN DEERE FINANCIAL | RU STREET MAINTENANCE SUPPLIE | 35.00 |

| Name | Description | Invoice Amount |
|--|--------------------------------|----------------|
| JOHN DEERE FINANCIAL | RU STREET MAINTENANCE SUPPLIE | 19.98 |
| Total 110-210: Road Use | | 15,994.05 |
| DAKOTA SUPPLY GROUP INC | RU SNOW REMOVAL | 715.00 |
| JERRY MCELMEEL | RU SNOW REMOVAL | 2,250.00 |
| Total 110-250: Snow Removal | | 2,965.00 |
| CENTER POINT PUBLISHING | LIB GEHRET BOOKS | 49.14 |
| Total 178-410: Library Slavka Gehret Trust | | 49.14 |
| SNYDER & ASSOCIATES INC | STEPHENS SEWER EXTENSION | 7,475.30 |
| Total 332-750: Capital Projects | | 7,475.30 |
| HENICK TREE SERVICE LLC | SIXTH STREET DITCH PROJECT | 14,950.00 |
| JONES COUNTY RECORDER | CAP IMP SIXTH ST DITCH EASEMEN | 334.00 |
| SNYDER & ASSOCIATES INC | SIXTH STREET DITCH PROJECT | 10,111.95 |
| Total 332-865: Sixth St. Ditch | | 25,395.95 |
| HAWKINS WATER TREATMENT | WATER EQUIP REPAIR/MAINT | 388.82 |
| ALLIANT ENERGY-IES | 18540 190TH ST WATER TOWER | 251.23 |
| INSURANCE ASSOCIATES INC. | WATER PROPERTY INSURANCE | 17,303.81 |
| DAWN MCELMEEL | OVERPAYMENT REFUND - MICHAEL | 24.79 |
| ROGER STEPHEN | OVERPAYMENT REFUND - KAIN HAR | 24.84 |
| MUNICIPAL SUPPLY INC | WATER SUPPLIES | 1,542.35 |
| ELECTRIC PUMP INC | WATER SYSTEM | 2,097.00 |
| HAWKINS WATER TREATMENT | WATER SYSTEM | 510.96 |
| Total 600-810: Water | | 22,143.80 |
| CITY OF MONTICELLO | WATER DEPOSIT REFUND - EGGIMA | 50.00 |
| CITY OF MONTICELLO | WATER DEPOSIT REFUND - EVANS | 150.00 |
| CITY OF MONTICELLO | WATER DEPOSIT REFUND - MASHEK | 124.99 |
| DANIELLE MASHEK | WATER DEPOSIT REFUND | 25.01 |
| Total 602-810: Water Deposits | | 350.00 |
| ACCENT CONCRETE LLC | WATER WEST WELL GENERATOR | 6,576.00 |
| Total 604-810: Water Capital Improvements | | 6,576.00 |
| BOWKER PINNACLE HOLDINGS INC | SEWER EQUIP REPAIR/MAINT | 1,791.90 |
| THEODORE KRAUS | SEWER EQUIP REPAIR/MAINT | 527.03 |
| CASCADE COMMUNICATIONS CO | SEWER UTILITIES | 99.00 |
| JONES COUNTY RECORDER | SEWER EASEMENT -MIKE & EMILY K | 17.00 |
| INSURANCE ASSOCIATES INC. | SEWER PROPERTY INSURANCE | 38,144.93 |
| DAWN MCELMEEL | OVERPAYMENT REFUND - MICHAEL | 33.60 |
| JANITH CRATSENBERG | OVERPAYMENT REFUND - HOLLY KR | 394.88 |
| JOHN DEERE FINANCIAL | SEWER SUPPLIES | 10.98 |
| JOHN DEERE FINANCIAL | SEWER SUPPLIES | 44.99 |
| FAREWAY STORES #840-1 | SEWER LAB SUPPLIES | 22.05 |
| BEHREND'S CRUSHED STONE | SEWER SYSTEM | 342.09 |
| ELECTRIC PUMP INC | SEWER SYSTEM | 845.00 |

| Name | Description | Invoice Amount |
|-----------------------------|--------------------------------|----------------|
| ELECTRIC PUMP INC | SEWER SYSTEM | 1,222.00 |
| HAWKINS WATER TREATMENT | SEWER SYSTEM | 1,937.50 |
| J&R RENTAL | SEWER SYSTEM | 1,197.20 |
| J&R SUPPLY INC | SEWER SYSTEM | 727.00 |
| PIRC-TOBIN CONSTRUCTION INC | SEWER SYSTEM | 7,330.85 |
| Total 610-815: Sewer | | 54,688.00 |
| DORSEY & WHITNEY LLP | SEWER GO EQUIP BOND, SERIES 20 | 9,000.00 |
| Total 613-815: Sewer | | 9,000.00 |
| INSURANCE ASSOCIATES INC. | SANITATION PROPERTY INSURANC | 3,390.85 |
| REPUBLIC SERVICES #897 | RESIDENTIAL RECYCLING | 9,603.88 |
| REPUBLIC SERVICES #897 | RESIDENTIAL GARBAGE | 22,690.16 |
| DAWN MCELMEEL | OVERPAYMENT REFUND - MICHAEL | 50.22 |
| Total 670-840: Sanitation | | 35,735.11 |
| ALLIANT ENERGY-IES | 22411 BUSINESS HWY 151 | 35.28 |
| SYCAMORE MEDIA CORP | YARD WASTE ADVERTISING | 91.20 |
| DUBUQUE MULCH CO | YARD WASTE COMPOST | 8,000.00 |
| Total 675-840: Yard Waste | | 8,126.48 |
| DAWN MCELMEEL | OVERPAYMENT REFUND - MICHAEL | 3.67 |
| Total 740-865: Stormwater | | 3.67 |
| Total : | | 388,522.76 |
| Grand Totals: | | 388,522.76 |

Report Criteria:
 [Report].Due Date = 04/07/2026

City Council Meeting
Prep. Date: 4/2/2026
Preparer: Sally Hinrichsen



Agenda Item: # 1
Agenda Date: 4/6/2026

Communication Page

Agenda Items Description: Resolution scheduling Public Hearing on the City of Monticello 2026/2027 Fiscal Year budget

Type of Action Requested: Motion; **Resolution**; Ordinance; Report; Public Hearing; Closed Session

Attachments & Enclosures:

| |
|---------------------|
| Proposed Resolution |
| |
| |

Fiscal Impact:

| | |
|-------------------|--|
| Budget Line Item: | |
| Budget Summary: | |
| Expenditure: | |
| Revenue: | |

Synopsis: Scheduling Public Hearing on FY '27 Budget approval for April 20, 2026.

Background Information: Public hearing required prior to approval of annual budget. Notice will be published in the Express as required by the Iowa Code.

Staff Recommendation: Recommend that the Council approve the proposed resolution scheduling public hearing on the proposed FY '27 budget for April 20, 2026 at 6:00 p.m.

City of Monticello, Iowa

RESOLUTION

Scheduling Public Hearing on the City of Monticello 2026/2027 Fiscal Year budget for April 20, 2026 at 6:00 p.m.

WHEREAS, The Iowa Code requires that that the City of Monticello hold a Public Hearing on the proposed budget for the coming fiscal year, prior to the final approval of same, and

WHEREAS, The budget must be entered into the Department of Management website by no later than April 30, 2026, and

WHEREAS, Notice of the Public Hearing must be published at least four days before but no more than twenty days prior to the Public Hearing, and

WHEREAS, Notice shall be published in the Monticello Express on the 15th day of April, 2026, scheduling Public Hearing for the 20th day of April 2026 at 6:00 P.M. at the, City Council Chambers at the Mary Lovell LeVan Renaissance Center, Monticello, Iowa, and

WHEREAS, The City Clerk is instructed to see to the publication of the appropriate Notice in the Monticello Express, consistent with the above dates, so that the Public Hearing may be held as scheduled herein.

NOW, THEREFORE, BE IT RESOLVED that the City Council of Monticello, Iowa does hereby schedule Public Hearing on the proposed 2026/2027 budget for the 20th day of April 2026 at 6:00 p.m. to be held in the City Council Chambers at the Mary Lovell LeVan Renaissance Center in Monticello, Iowa.

IN TESTIMONY WHEREOF, I have hereunto subscribed my name and caused the Great Seal of the City of Monticello, Iowa to be affixed hereto.
Done this 6th day of April, 2026.

Jake Ellwood, Mayor

Attest:

Sally Hinrichsen, City Clerk/Treasurer

City Council Meeting
Prep. Date: 03/24/2026
Preparer: Lori Lynch



Agenda Item: # 2
Agenda Date: 04/06/2026

Communication Page

Agenda Items Description: Purchase of EMT3 9 Position Rapid Response Kits

Type of Action Requested: Resolution;

Attachments & Enclosures:

Invoice for MCI bags

Fiscal Impact:

Budget Line Item:

Budget Summary:

Expenditure:

Revenue:

\$5,946.80

\$5,946.80

Synopsis: Purchasing 4 EMT3 9 Position Rapid Response Kits, also called MCI bags.

Background Information: Recently it was noted that our current Mass Casualty bag is out of date and no longer usable. An anonymous donor has agreed to purchase 4 of these bags for the service. A Mass casualty is any event that exhausted the resources available at the time of the event. The last bag was purchased about ten years ago. The only impact this purchase will have on the budget is a needed amendment to move money into the correct line item. Donation covers the entire purchase.

Staff Recommendation: Director Lynch recommends purchasing these bags.

City of Monticello, Iowa

RESOLUTION

Approving the purchase of EMT3 9 Position Rapid Response Kits for the Monticello Ambulance Service

WHEREAS, the City of Monticello Ambulance Service received a donation to purchase 4 - EMT3 9 Position Rapid Response Kits, which are also call Mass Casualty bags (MCI) for the Monticello Ambulance Department, and

WHEREAS, the Ambulance Director received a price quote for these kits and has recommended the purchase of EMT3 9 Position Rapid Response Kits from Bound Tree, in the quoted amount of \$5, 946.80, and the budget to be amended for this purchase, and

WHEREAS, the Council finds that, based upon the recommendation of the Ambulance Director, that the purchase of 4 – EMT3 9 Position Rapid Response Kits in the amount of \$5,946.80 to be purchased in FY 2026, is in the best interests of the City of Monticello Ambulance Department and should, therefore, be approved and the budget to be amended accordingly.

NOW, THEREFORE, BE IT RESOLVED that the City Council of Monticello, Iowa does hereby approve of the purchase of the EMT3 9 Position Rapid Response Kits, as proposed by the Ambulance Director from Bound Tree, as stated above.

IN TESTIMONY WHEREOF, I have hereunto subscribed my name and caused the Great Seal of the City of Monticello, Iowa to be affixed hereto. Done this 6th day of April, 2026.

Jake Ellwood, Mayor

Attest:

Sally Hinrichsen, City Clerk/Treasurer



Quotation

Quotation#: QUO-147161-J5C8W6

Last Modified: 03/04/2026 8:03 AM

Customer PO #:

Account Number: 113915SHIP003

Bill To:

MONTICELLO AMBULANCE SHIP003
201 E SOUTH ST
MONTICELLO, IA 52310-1919

Ship Method:

Payment Terms:

Ship To:

MONTICELLO AMBULANCE SHIP003
201 E SOUTH ST
MONTICELLO, IA 52310-1919

| Item | Description | UOM | QTY | List Price | Your Price | Ext. Price |
|-----------|------------------------------------|-----|-----|------------|------------|------------|
| DMS-05001 | EMT3 9 Position Rapid Response Kit | EA | 4 | \$1,689.99 | \$1,486.70 | \$5,946.80 |

Quote Total: \$5,946.80

Quote Expiration Date: 05/25/2026

Comments:

Justin Derghazarian

Bound Tree | Remote Sales Account Manager
5000 Tuttle Crossing Blvd, Dublin OH 43016
Office Phone: 614-760-5283 | Mobile Phone:
Justin.Derghazarian@boundtree.com

Sales Tax will be applied to customers who are not exempt.

Shipping charges will be prepaid and added to the invoice unless otherwise stated.

Should there be any price increases, taxes, tariffs, duties, surcharges or other fees imposed by the government, manufacturer, and/or supplier on any product(s) included in this quote, Bound Tree Medical reserves the right to amend the pricing contained in the quote.

To place an order, visit our website at www.boundtree.com, log in, and add items to your shopping cart. Alternatively, you can call (800) 533-0523 or fax (800) 257-5713.

City Council Meeting
 Prep. Date: 4/2/2026
 Preparer: Sally Hinrichsen



Agenda Item: # 3
 Agenda Date: 4/6/2026

Communication Page

Agenda Items Description: Resolution Approving Jones County Safe & Healthy Coalition Investment and agreement for FY '27 in the amount of \$3,000.00

Type of Action Requested: Motion; **Resolution**; Ordinance; Report; Public Hearing; Closed Session

Attachments & Enclosures:

| |
|---------------------|
| Proposed Resolution |
| Request for funding |
| Agreement |

Fiscal Impact:

| | |
|-------------------|-----------------------|
| Budget Line Item: | |
| Budget Summary: | Admin County Contrib. |
| Expenditure: | \$3000 |
| Revenue: | |

Synopsis: Jones County Safe & Healthy Youth Coalition request funding.

Background Information: Iowa Auditor of State has provided guidance regarding the Iowa Constitution Article III, Section 31 and guidance for the City to give funds to private entities and the importance to identify and ensure the funds are serving a public purpose. No public money or property shall be appropriated for local, or private purpose, unless such appropriation, compensation, or claim, be allowed by two thirds of the members elected. It is a requirement that public funds be spent for the public benefit and/or purpose. Council should determine their finding of the “Public Purpose”. An Agreement, with the private entity, setting out the facts and rationale for how the public will benefit from the transfer of public funds to the private entity. The agreement should be approved by resolution of the Council

The attached letter explains the request for funding from Jones County Safe & Healthy Youth Coalition.

The Coalition has requested \$3,000 consistent with last year’s request.

Recommendation: Recommendation that the Council take appropriate action on the Jones County Safe & Healthy Youth Coalition request for funding

City of Monticello, Iowa

RESOLUTION

Approving Jones County Safe & Healthy Coalition Investment and agreement for FY '27 in the amount of \$3,000.00

WHEREAS, the City of Monticello, Iowa is an incorporated City within Jones County, Iowa, and

WHEREAS, The City of Monticello has received a request for Jones County Safe & Healthy Youth Coalition to provide funding in the amount of \$3,000.00 to support youth prevention efforts, and

WHEREAS, The City first provided funding to the Coalition in FY '20 in the amount of \$2,000.00 and since FY '22 in the amount of \$3,000.00, the Coalition previously being funded by grants that are reportedly no longer received, and

WHEREAS, the Monticello City Council reviewed agreement with Jones County Safe & Healthy Youth Coalition to support continued youth prevention efforts, and

WHEREAS, the Agreement with the above entity is subject to renewal annually, with the agreement for FY '27 being presented for approval in the amount of \$3,000.00, and

WHEREAS, the Monticello City Council has considered the request made by Jones County Safe & Healthy Youth Coalition, and has determined it appropriate to invest in the Jones County Safe & Healthy Youth Coalition.

NOW THEREFORE BE IT RESOLVED by the City of Monticello, through its' City Council, in session this 6th day of April, 2026 that the City of Monticello does hereby approve the agreement with Jones County Safe & Healthy Youth Coalition, previously mentioned herein, and does hereby authorize the Mayor to execute the same on behalf of the City Council.

IN TESTIMONY WHEREOF, I have hereunto subscribed my name and caused the Great Seal of the City of Monticello, Iowa to be affixed hereto. Done this 6th day of April 2026.

Jake Ellwood, Mayor

Attest:

Sally Hinrichsen, City Clerk/Treasurer

**CITY OF MONTICELLO AND JONES
COUNTY SAFE AND HEALTHY YOUTH
COALITION SOCIAL SERVICES FUNDING
AGREEMENT FOR NON-PROFIT
ORGANIZATIONS**

This Social Services Funding Agreement (“Agreement”) is entered into by and between the Jones County Safe and Healthy Youth Coalition (hereinafter referred to as “Provider” which expression shall include its agents, successors or assigns) and the City of Monticello, Iowa (hereinafter “the City”). Provider and the City are collectively referred to as “the Parties.”

I. RECITALS

A. The City of Monticello, Iowa is committed to protecting and preserving the health, safety and welfare of its residents.

B. The City finds that providing funding for certain charitable and not-for-profit enterprises which directly serve and benefit the residents of Monticello is an effective and efficient means to those ends, particularly in regard to underserved portions of the population.

C. Provider is a charitable or not-for-profit organization which offers the following services benefiting residents of Monticello (the “Services”):

The Coalition engages communities in efforts to promote mental wellness and reduce substance use by creating and maintaining a safe and healthy environment for youth and adults in Jones County. The goal is that every child in Jones County has a safe and healthy family and community so that they can thrive into the future.

D. The City finds that the Services offered by Provider serve an important public purpose for beautification and help to promote the health, safety and welfare of residents of Monticello.

E. Provider has asked the City for financial assistance which will allow the Provider to offer the Services to City residents in the coming fiscal year. The City finds that a payment to Provider to help ensure its ongoing operations is a reasonable and appropriate use of public funds.

II. TERMS

1. **Recitals.** By this reference, the Recitals set forth above are incorporated into and made part of this Agreement.

2. **Consideration.** Upon execution of this Agreement by all Parties and upon approval

of the Agreement by the City's council, the City shall pay Provider the sum of \$3,000 (Three Thousand). In return, Provider agrees to provide the Services to residents of Monticello as part of its ongoing operations. Funds will be paid after expenditures have been made by the Provider. If the Provider can show a hardship from the payment being made after the expenses have been incurred, the City will consider a payment immediately prior to the expense being made, if proof of the expense is provided.

3. **Accounting.** Provider agrees to allocate said funds in accordance with its operational goals to provide the Services to area residents, including residents of Monticello, and to provide an annual accounting to the City showing that the funds were so applied. Annual accounting will include a summary of funds received and spent and receipts totally at least the total amount contributed by the City.

4. **Interpretation.** The language of all parts of this Agreement shall in all cases be construed as a whole, according to its fair meaning, and not strictly for or against any of the Parties. This Agreement is made and entered into, and shall be subject to, governed by, and interpreted in accordance with, the laws of the State of Iowa.

5. **Severability.** Should any provision of this Agreement be declared or be determined by any court to be illegal or invalid, the validity of the remaining parts, terms, or provisions shall not be affected thereby and said illegal or invalid part, term, or provision shall be deemed not to be a part of this Agreement.

6. **Entire Agreement.** This Agreement sets forth the entire agreement between the Parties hereto and fully supersedes any and all prior agreements or understanding between the Parties hereto pertaining to the subject matter hereof.

7. **Counterparts.** This Agreement shall be executed in one or more counterparts and by facsimile or other electronic means, each counterpart shall, for all purposes, be deemed an original, and all counterparts shall constitute the same instrument.

8. **Authority to Sign.** The undersigned individuals represent and warrant that they have authority to execute the Agreement on behalf of their respective parties. The undersigned individuals represent and warrant that all necessary corporate actions or resolutions have been taken to authorize the execution of this Agreement.

9. **Drafting.** This Agreement was negotiated at arm's-length and entered into freely by the Parties, who have had opportunity to seek the advice of counsel. In the event an ambiguity exists in any provision of this Agreement, such ambiguity is not to be construed by reference to any doctrine or statute calling for ambiguities to be construed against the drafter of the document.

10. **Captions.** The captions or headings of the sections in this Agreement are for the

convenience of reference only and in no way define, limit, or affect the scope or substance of any section of this Agreement.

11. **Scope of Promises, Representations, and Inducements.** Parties acknowledge, warrant and represent that no promises, representation or inducements, except as herein set forth, have been offered or made by a party hereto or to any other party hereto to secure the execution of any provision of this Agreement.

12. **Successors and Assigns.** This Agreement shall be binding upon and inure to the benefit of each Party's successors and assigns.

13. **Modifications.** No part or provision of this Agreement may be changed, modified, waived, discharged or terminated except by an instrument in writing signed by the Party against whom enforcement of such change, modification, waiver, discharge or termination is sought. The failure of a party to seek redress for violation of, or to insist upon strict performance of, any provision of this Agreement shall not be a waiver of that provision by the party to estop that party from asserting fully any and all of its rights under this Agreement.

14. **Further Assurances.** Each party shall execute such other and further documents, and take such other and further actions as may be reasonably requested by a Party hereto for the purpose effectuating the agreements herein.

IN WITNESS WHEREOF, the Parties hereto have executed this Social Services Funding Agreement effective on the last date set forth below.

JONES COUNTY SAFE AND HEALTHY YOUTH COALITION, Provider

By: _____

Date of Signature: _____

City of Monticello, Iowa

By: _____

Jake Ellwood, Mayor

Date of Signature: _____

City Council Meeting
Prep. Date: 4/2/2026
Preparer: Sally Hinrichsen



Agenda Item: # 4
Agenda Date: 4/6/2026

Communication Page

Agenda Items Description: Resolution Approving Maquoketa River Watershed Management Authority investment and agreement for FY '27 in the amount of \$3,030.00, plus five (5) water sampling locations

Type of Action Requested: Motion; **Resolution**; Ordinance; Report; Public Hearing; Closed Session

Attachments & Enclosures:

| |
|---------------------|
| Proposed Resolution |
| Agreement |
| |

Fiscal Impact:

| | |
|-------------------|--|
| Budget Line Item: | |
| Budget Summary: | Admin County Contrib. |
| Expenditure: | \$3,030 plus five (5) water sampling locations |

Synopsis: Maquoketa River Watershed Management Authority requests funding from the City to address water quality, water quantity (flooding) as well as other issues associated with the Maquoketa River watershed area.

Background Information: Iowa Auditor of State has provided guidance regarding the Iowa Constitution Article III, Section 31 and guidance for the City to give funds to private entities and the importance to identify and ensure the funds are serving a public purpose. No public money or property shall be appropriated for local, or private purpose, unless such appropriation, compensation, or claim, be allowed by two thirds of the members elected. It is a requirement that public funds be spent for the public benefit and/or purpose. Council should determine their finding of the “Public Purpose”. An Agreement, with the private entity, setting out the facts and rationale for how the public will benefit from the transfer of public funds to the private entity. The agreement should be approved by resolution of the Council

The Maquoketa River Watershed Management Authority (MR WMA) was formed in 2017. Limestone Bluff RC&D is the official fiscal agent for the organization and is currently providing in nonprofit umbrella, grant writing services and overall management.

Financial support for MR WMA is voluntary for its members, which consists of 34 Cities, Counties, Soil and Water Conservation Districts and a Lake District in Eastern Iowa.

The MR WMA has executed its water monitoring program, testing 36 sites three times a year. MR WMA is working with the University of Iowa’s Planning Students who are completing the phase II of our Watershed Management Plan.

Recommendation: Recommendation that the Council take appropriate action on the Maquoketa River Watershed Management Authority request for \$3,030.00 and \$270.00 for the five water sampling locations.

City of Monticello, Iowa

RESOLUTION

Approving Maquoketa River Watershed Management Authority
Investment and Agreement for FY '26 in the amount of \$3,030.00,
plus five (5) water sampling locations

WHEREAS, The City of Monticello is a member of the Maquoketa River Watershed Management Authority (MR WMA), and

WHEREAS, The City Council finds that the MR WMA has requested a per capita assessment from all members to support the costs of administering the MR WMA during the creation of the Watershed Management Plan, a process that is underway. MR WMA is working on the stakeholder survey, which is open to all residents of Monticello, and

WHEREAS, MR WMA has requested \$0.75 per capital which is \$3,030.00 plus five (5) water sampling locations in the amount of \$270.00, for a total of \$3,300.00; as the City of Monticello FY '27 investment, which is the same amount requested in FY '26, and

WHEREAS, the Monticello City Council reviewed agreement with MR WMA to support the Maquoketa River Watershed Management Plan, implementation of conservation practices, and water monitoring program, and

WHEREAS, the Agreement with the above entity is subject to renewal annually, with the agreement for FY '27 being presented for approval in the amount of \$3,030.00, plus five (5) water sampling locations, and

WHEREAS, the Monticello City Council has considered the request made by MR WMA, and has determined it appropriate to invest in the MR WMA Program, and.

NOW THEREFORE BE IT RESOLVED by the City of Monticello, through its' City Council, in session this 6th day of April, 2026 that the City of Monticello does hereby approve the agreement with MR WMA, previously mentioned herein, and does hereby authorize the Mayor to execute the same on behalf of the City Council.

IN TESTIMONY WHEREOF, I have hereunto
subscribed my name and caused the Great Seal
of the City of Monticello, Iowa to be affixed hereto.
Done this 6th day of April, 2026.

Jake Ellwood, Mayor

Attest:

Sally Hinrichsen, City Clerk/Treasurer

**CITY OF MONTICELLO MAQUOKETA
RIVER WATERSHED MANAGEMENT
AUTHORITY SOCIAL SERVICES FUNDING
AGREEMENT FOR NON-PROFIT
ORGANIZATIONS**

This Social Services Funding Agreement (“Agreement”) is entered into by and between the Maquoketa River Watershed Management Authority (MR WMA) (hereinafter referred to as “Provider” which expression shall include its agents, successors or assigns) and the City of Monticello, Iowa (hereinafter “the City”). Provider and the City are collectively referred to as “the Parties.”

I. RECITALS

A. The City of Monticello, Iowa is committed to protecting and preserving the health, safety and welfare of its residents.

B. The City finds that providing funding for certain charitable and not-for-profit enterprises which directly serve and benefit the residents of Monticello is an effective and efficient means to those ends, particularly in regard to underserved portions of the population.

C. Provider is a charitable or not-for-profit organization which offers the following services benefiting residents of Monticello (the “Services”):

The Provider engages communities in efforts to promote and maintain a safe and healthy environment for youth and adults in Monticello and Jones County. The goal and objectives of our project include the ongoing work of the Maquoketa River WMA to implement the Watershed Management Plan completed in FY 23 and conduct meaningful outreach related to implementation of the plan. The plan will identify priority area where implementation of conservation practices will have maximum impacts. The MR WMA will also continue a water monitoring program with the testing of 45 sites across the watershed (5 in Jones County); delivery of educational events on watershed related issues in member communities and active support of conservation efforts within the watershed area. To accomplish this work, the MR WMA needs sustained efforts of a dedicated watershed coordinator and support from LB RC&D. The work of the Maquoketa River WMA will positively impact the water quality, water quantity and soil health in the watershed for generations to come, protecting public health and supporting municipal and agricultural economies across Eastern Iowa.

D. The City finds that the Services offered by Provider serve an important public purpose for beautification and help to promote the health, safety and welfare of residents of Monticello.

E. Provider has asked the City for financial assistance which will allow the Provider

to offer the Services to City residents in the coming fiscal year. The City finds that a payment to Provider to help ensure its ongoing operations is a reasonable and appropriate use of public funds.

II. TERMS

1. **Recitals.** By this reference, the Recitals set forth above are incorporated into and made part of this Agreement.

2. **Consideration.** Upon execution of this Agreement by all Parties and upon approval of the Agreement by the City's council, the City shall pay Provider the sum of \$3,030 (Three Thousand Thirty), plus assisting with five water sampling locations for an additional \$270 (Two hundred Seventy). In return, Provider agrees to provide the Services to residents of Monticello as part of its ongoing operations. Funds will be paid after expenditures have been made by the Provider. If the Provider can show a hardship from the payment being made after the expenses have been incurred, the City will consider a payment immediately prior to the expense being made, if proof of the expense is provided.

3. **Accounting.** Provider agrees to allocate said funds in accordance with its operational goals to provide the Services to area residents, including residents of Monticello, and to provide an annual accounting to the City showing that the funds were so applied. Annual accounting will include a summary of funds received and spent and receipts totaling at least the total amount contributed by the City.

4. **Interpretation.** The language of all parts of this Agreement shall in all cases be construed as a whole, according to its fair meaning, and not strictly for or against any of the Parties. This Agreement is made and entered into, and shall be subject to, governed by, and interpreted in accordance with, the laws of the State of Iowa.

5. **Severability.** Should any provision of this Agreement be declared or be determined by any court to be illegal or invalid, the validity of the remaining parts, terms, or provisions shall not be affected thereby and said illegal or invalid part, term, or provision shall be deemed not to be a part of this Agreement.

6. **Entire Agreement.** This Agreement sets forth the entire agreement between the Parties hereto and fully supersedes any and all prior agreements or understanding between the Parties hereto pertaining to the subject matter hereof.

7. **Counterparts.** This Agreement shall be executed in one or more counterparts and by facsimile or other electronic means, each counterpart shall, for all purposes, be deemed an original, and all counterparts shall constitute the same instrument.

8. **Authority to Sign.** The undersigned individuals represent and warrant that they

have authority to execute the Agreement on behalf of their respective parties. The undersigned individuals represent and warrant that all necessary corporate actions or resolutions have been taken to authorize the execution of this Agreement.

9. **Drafting.** This Agreement was negotiated at arm's-length and entered into freely by the Parties, who have had opportunity to seek the advice of counsel. In the event an ambiguity exists in any provision of this Agreement, such ambiguity is not to be construed by reference to any doctrine or statute calling for ambiguities to be construed against the drafter of the document.

10. **Captions.** The captions or headings of the sections in this Agreement are for the convenience of reference only and in no way define, limit, or affect the scope or substance of any section of this Agreement.

11. **Scope of Promises, Representations, and Inducements.** Parties acknowledge, warrant and represent that no promises, representation or inducements, except as herein set forth, have been offered or made by a party hereto or to any other party hereto to secure the execution of any provision of this Agreement.

12. **Successors and Assigns.** This Agreement shall be binding upon and inure to the benefit of each Party's successors and assigns.

13. **Modifications.** No part or provision of this Agreement may be changed, modified, waived, discharged or terminated except by an instrument in writing signed by the Party against whom enforcement of such change, modification, waiver, discharge or termination is sought. The failure of a party to seek redress for violation of, or to insist upon strict performance of, any provision of this Agreement shall not be a waiver of that provision by the party to estop that party from asserting fully any and all of its rights under this Agreement.

14. **Further Assurances.** Each party shall execute such other and further documents, and take such other and further actions as may be reasonably requested by a Party hereto for the purpose effectuating the agreements herein.

IN WITNESS WHEREOF, the Parties hereto have executed this Social Services Funding Agreement effective on the last date set forth below.

MAQUOKETA RIVER WATERSHED MANAGEMENT AUTHORITY, Provider

By: _____

Date of Signature: _____

City of Monticello, Iowa

By: _____
 Jake Ellwood, Mayor

Date of Signature: _____

City Council Meeting
Prep. Date: 4/2/2026
Preparer: Sally Hinrichsen



Agenda Item: # 5
Agenda Date: 4/6/2026

Communication Page

Agenda Items Description: Resolution Approving Jones County Economic Development (JCED) Investment and agreement for FY '27

Type of Action Requested: Motion; **Resolution**; Ordinance; Report; Public Hearing; Closed Session

Attachments & Enclosures:

| |
|---------------------|
| Proposed Resolution |
| Agreement |
| |

Fiscal Impact:

| | |
|-------------------|--------------|
| Budget Line Item: | |
| Budget Summary: | Hotel/motel. |
| Expenditure: | \$15,000 |
| Revenue: | |

Synopsis: Request of annual appropriation for Jones County Economic Development.

Background Information: Iowa Auditor of State has provided guidance regarding the Iowa Constitution Article III, Section 31 and guidance for the City to give funds to private entities and the importance to identify and ensure the funds are serving a public purpose. No public money or property shall be appropriated for local, or private purpose, unless such appropriation, compensation, or claim, be allowed by two thirds of the members elected. It is a requirement that public funds be spent for the public benefit and/or purpose. Council should determine their finding of the “Public Purpose”. An Agreement, with the private entity, setting out the facts and rationale for how the public will benefit from the transfer of public funds to the private entity. The agreement should be approved by resolution of the Council

The City of Monticello has been an investor or partner with Jones County Economic Development for many years. The amount requested \$15,000 and and \$4,000 in in-kind office and internet services is consistent with the City’s investment since FY ’23.

Economic Development is often difficult to measure. An active Economic Development partner can be a great asset and this has been the case with Jones County Economic Development under Derek Lumsden. Actual economic development is imperative to the health of our community, whether this \$15,000 investment will create economic development may be hard to ascertain, but if it generates one new business, building or Job we would see a return. Derek has been very helpful on many fronts, with Compadres building and Wastewater Treatment Plant grant and many other grant applications. He continues to work on Grant Opportunities and other opportunities.

Successes that have been due to the involvement of Jones County Economic Development in Monticello include the following: Complete restoration and rehabilitation of the Compadres building into a quality restaurant; Monticello being designated as an Iowa Main Street program; Site selection

and initial meetings with Hy-Vee Dollar Fresh; and the new Home for Iowa house located at 303 West Sixth Street lot.

Other successes in Jones County that have impacted Monticello through Jones County Economic Development include, but are not limited to: Eastern Iowa Fiber and Cascade Communications running more fiber lines to and through the City; Partnering with the City to develop a program to bring more funding to affordable housing options in Monticello; Collaborating with local and county entities for tourism; and operating the 24/7 Jones County Business Lab.

Recommendation: Recommendation that the Council take appropriate action on the Jones County Economic Development request for funding

City of Monticello, Iowa

RESOLUTION

Approving Jones County Economic Development (JCED) Investment and agreement for FY '27 in the amount of \$15,000.00 and \$4,000 in in-kind office and internet services

WHEREAS, the City of Monticello, Iowa is an incorporated City within Jones County, Iowa, and

WHEREAS, the City of Monticello has partnered with the Jones County for a number of years. The annual investment amount requested by JCED is \$15,000.00 in cash and \$4,000 in in-kind office and internet services, and

WHEREAS, the Council finds that the relationship by and between JCED and the City of Monticello is mutually beneficial and that the City should continue to invest in the JCED, and

WHEREAS, the Monticello City Council reviewed agreement with JCED to support the County Economic Development, and

WHEREAS, the Agreement with the above entity is subject to renewal annually, with the agreement for FY '27 being presented for approval in the amount of \$15,000.00 in cash and \$4,000 in in-kind office and internet services, and

WHEREAS, the Monticello City Council has considered the request made by JCED, and has determined it appropriate to invest in the JCED.

NOW THEREFORE BE IT RESOLVED by the City of Monticello, through its' City Council, in session this 6th day of April, 2026 that the City of Monticello does hereby approve the agreement with JCED, previously mentioned herein, and does hereby authorize the Mayor to execute the same on behalf of the City Council.

IN TESTIMONY WHEREOF, I have hereunto subscribed my name and caused the Great Seal of the City of Monticello, Iowa to be affixed hereto. Done this 6th day of April, 2026.

Jake Ellwood, Mayor

Attest:

Sally Hinrichsen, City Clerk/Treasurer

**CITY OF MONTICELLO AND JONES
COUNTY ECONOMIC DEVELOPMENT
(JCED) SOCIAL SERVICES FUNDING
AGREEMENT FOR NON-PROFIT
ORGANIZATIONS**

This Social Services Funding Agreement (“Agreement”) is entered into by and between the Jones County Economic Development Commission (hereinafter referred to as “Provider” which expression shall include its agents, successors or assigns) and the City of Monticello, Iowa (hereinafter “the City”). Provider and the City are collectively referred to as “the Parties.”

I. RECITALS

A. The City of Monticello, Iowa is committed to protecting and preserving the health, safety and welfare of its residents.

B. The City finds that providing funding for certain charitable and not-for-profit enterprises which directly serve and benefit the residents of Monticello is an effective and efficient means to those ends, particularly in regard to underserved portions of the population.

C. Provider is a charitable or not-for-profit organization which offers the following services benefiting residents of Monticello (the “Services”):

The JCED provides grant research, writing, and project management where necessary; continued Business Retention, Recruiting, and Expansion activities; childcare and housing research and solutions implementation (where feasible); and other area of interest.

D. The City finds that the Services offered by Provider serve an important public purpose for beautification and help to promote the health, safety and welfare of residents of Monticello.

E. Provider has asked the City for financial assistance which will allow the Provider to offer the Services to City residents in the coming fiscal year. The City finds that a payment to Provider to help ensure its ongoing operations is a reasonable and appropriate use of public funds.

II. TERMS

1. **Recitals.** By this reference, the Recitals set forth above are incorporated into and made part of this Agreement.

2. **Consideration.** Upon execution of this Agreement by all Parties and upon approval of the Agreement by the City’s council, the City shall pay Provider the sum of \$15,000 (Fifteen

Thousand) in cash and \$4,000 in in-kind office and internet services. In return, Provider agrees to provide the Services to residents of Monticello as part of its ongoing operations. Funds will be paid after expenditures have been made by the Provider. If the Provider can show a hardship from the payment being made after the expenses have been incurred, the City will consider a payment immediately prior to the expense being made, if proof of the expense is provided.

3. **Accounting.** Provider agrees to allocate said funds in accordance with its operational goals to provide the Services to area residents, including residents of Monticello, and to provide an annual accounting to the City showing that the funds were so applied. Annual accounting will include a summary of funds received and spent and receipts totally at least the total amount contributed by the City.

4. **Interpretation.** The language of all parts of this Agreement shall in all cases be construed as a whole, according to its fair meaning, and not strictly for or against any of the Parties. This Agreement is made and entered into, and shall be subject to, governed by, and interpreted in accordance with, the laws of the State of Iowa.

5. **Severability.** Should any provision of this Agreement be declared or be determined by any court to be illegal or invalid, the validity of the remaining parts, terms, or provisions shall not be affected thereby and said illegal or invalid part, term, or provision shall be deemed not to be a part of this Agreement.

6. **Entire Agreement.** This Agreement sets forth the entire agreement between the Parties hereto and fully supersedes any and all prior agreements or understanding between the Parties hereto pertaining to the subject matter hereof.

7. **Counterparts.** This Agreement shall be executed in one or more counterparts and by facsimile or other electronic means, each counterpart shall, for all purposes, be deemed an original, and all counterparts shall constitute the same instrument.

8. **Authority to Sign.** The undersigned individuals represent and warrant that they have authority to execute the Agreement on behalf of their respective parties. The undersigned individuals represent and warrant that all necessary corporate actions or resolutions have been taken to authorize the execution of this Agreement.

9. **Drafting.** This Agreement was negotiated at arm's-length and entered into freely by the Parties, who have had opportunity to seek the advice of counsel. In the event an ambiguity exists in any provision of this Agreement, such ambiguity is not to be construed by reference to any doctrine or statute calling for ambiguities to be construed against the drafter of the document.

10. **Captions.** The captions or headings of the sections in this Agreement are for the convenience of reference only and in no way define, limit, or affect the scope or substance of any

section of this Agreement.

11. **Scope of Promises, Representations, and Inducements.** Parties acknowledge, warrant and represent that no promises, representation or inducements, except as herein set forth, have been offered or made by a party hereto or to any other party hereto to secure the execution of any provision of this Agreement.

12. **Successors and Assigns.** This Agreement shall be binding upon and inure to the benefit of each Party's successors and assigns.

13. **Modifications.** No part or provision of this Agreement may be changed, modified, waived, discharged or terminated except by an instrument in writing signed by the Party against whom enforcement of such change, modification, waiver, discharge or termination is sought. The failure of a party to seek redress for violation of, or to insist upon strict performance of, any provision of this Agreement shall not be a waiver of that provision by the party to estop that party from asserting fully any and all of its rights under this Agreement.

14. **Further Assurances.** Each party shall execute such other and further documents, and take such other and further actions as may be reasonably requested by a Party hereto for the purpose effectuating the agreements herein.

IN WITNESS WHEREOF, the Parties hereto have executed this Social Services Funding Agreement effective on the last date set forth below.

JONES COUNTY ECONOMIC DEVELOPMENT, Provider

By: _____

Date of Signature: _____

City of Monticello, Iowa

By: _____

Jake Ellwood, Mayor

Date of Signature: _____

City Council Meeting
 Prep. Date 4/2/2026
 Preparer: Sally Hinrichsen



Agenda Item: #6
 Agenda Date: 4/6/2026

Communication Page

Agenda Items Description: Resolution Approving Monticello Firefighters of Iowa Organization Inc., planning of the Independence Day Fireworks festivities to be held on July 4, 2026 and authorizes payment in the amount of \$2,600.00 towards the fireworks

Type of Action Requested: Motion; Resolution; Ordinance; Report; Public Hearing; Closed Session

Attachments & Enclosures:

| |
|---------------------|
| Proposed Resolution |
| |
| |

Fiscal Impact:

| | |
|-------------------|-----------------------|
| Budget Line Item: | |
| Budget Summary: | Admin County Contrib. |
| Expenditure: | \$2,600.00 |
| Revenue: | |

Synopsis: Monticello Firefighters of Iowa Organization Inc. plan to sponsor the 4th of July festivities on Monday, July 4, 2026 and seek City investment.

Background Information: Iowa Auditor of State has provided guidance regarding the Iowa Constitution Article III, Section 31 and guidance for the City to give funds to private entities and the importance to identify and ensure the funds are serving a public purpose. No public money or property shall be appropriated for local, or private purpose, unless such appropriation, compensation, or claim, be allowed by two thirds of the members elected. It is a requirement that public funds be spent for the public benefit and/or purpose. Council should determine their finding of the “Public Purpose”. An Agreement, with the private entity, setting out the facts and rationale for how the public will benefit from the transfer of public funds to the private entity. The agreement should be approved by resolution of the Council

Monticello Firefighters of Iowa Organization Inc. will be planning and managing the 4th of July fireworks event.

The City has invested \$2,600.00 towards the fireworks the last number of years and the Firefighters are requesting the same contribution to be paid directly to the fireworks vendor.

Recommendation: A motion to approve is recommended.

CITY OF MONTICELLO, IOWA

RESOLUTION

Approving Monticello Firefighters of Iowa Organization Inc., planning of the Independence Day Fireworks festivities to be held on July 4, 2026 and authorizes payment in the amount of \$2,600.00 towards the fireworks

WHEREAS, the City of Monticello, Iowa is an incorporated City within Jones County, Iowa, and

WHEREAS, The Council has been advised that the Monticello Firefighters of Iowa Organization Inc., will be heading up this year's Independence Day fireworks festivities, and

WHEREAS, the Monticello City Council supports the Monticello Firefighters of Iowa Organization Inc., in the planning of the Independence Day fireworks festivities, and

WHEREAS, the Monticello City Council further supports the Independence Day fireworks event and authorizes payment in the amount of \$2,600.00 towards the fireworks, and

NOW THEREFORE BE IT RESOLVED by the City of Monticello, through its' City Council, in session this 6th day of April, 2026 that the City of Monticello does hereby authorize payment in the amount of \$2,600.00 towards the fireworks and supports the Monticello Firefighters of Iowa Organization Inc., in the planning of the Independence Day fireworks festivities.

IN TESTIMONY WHEREOF, I have hereunto subscribed my name and caused the Great Seal for the City of Monticello, Iowa to be affixed. Done this 6th day of April 2026.

Jake Ellwood, Mayor

Attest:

Sally Hinrichsen, City Clerk/Treasurer

**CITY OF MONTICELLO AND MONTICELLO
FIREFIGHTER’S ORGANIZATION SOCIAL
SERVICES FUNDING AGREEMENT FOR
NON-PROFIT ORGANIZATIONS**

This Social Services Funding Agreement (“Agreement”) is entered into by and between the Monticello Firefighters of IA Organization (hereinafter referred to as “Provider” which expression shall include its agents, successors or assigns) and the City of Monticello, Iowa (hereinafter “the City”). Provider and the City are collectively referred to as “the Parties.”

I. RECITALS

A. The City of Monticello, Iowa is committed to protecting and preserving the health, safety and welfare of its residents.

B. The City finds that providing funding for certain charitable and not-for-profit enterprises which directly serve and benefit the residents of Monticello is an effective and efficient means to those ends, particularly in regard to underserved portions of the population.

C. Provider is a charitable or not-for-profit organization which offers the following services benefiting residents of Monticello (the “Services”):

The Provider engages community in the City’s 4th of July celebration and fireworks, provided by Flashing Thunder on July 4, 2026; creating and maintaining a safe and healthy environment for youth and adults in Jones County to enjoy.

D. The City finds that the Services offered by Provider serve an important public purpose for safe and healthy environment for youth and adults in Monticello to enjoy fireworks and help to promote the health, safety and welfare of residents of Monticello.

E. Provider has asked the City for financial assistance which will allow the Provider to offer the Services to City residents in the coming fiscal year. The City finds that a payment to Provider to help ensure its ongoing operations is a reasonable and appropriate use of public funds.

II. TERMS

1. **Recitals.** By this reference, the Recitals set forth above are incorporated into and made part of this Agreement.

2. **Consideration.** Upon execution of this Agreement by all Parties and upon approval of the Agreement by the City’s council, the City shall pay Provider the sum of \$2,600 (Two Thousand Six Hundred). In return, Provider agrees to provide the Services to residents of

Monticello as part of its ongoing operations. Funds will be paid after expenditures have been made by the Provider. If the Provider can show a hardship from the payment being made after the expenses have been incurred, the City will consider a payment immediately prior to the expense being made, if proof of the expense is provided.

3. **Accounting.** Provider agrees to allocate said funds in accordance with its operational goals to provide the Services to area residents, including residents of Monticello, and to provide an annual accounting to the City showing that the funds were so applied. Annual accounting will include a summary of funds received and spent and receipts totally at least the total amount contributed by the City.

4. **Interpretation.** The language of all parts of this Agreement shall in all cases be construed as a whole, according to its fair meaning, and not strictly for or against any of the Parties. This Agreement is made and entered into, and shall be subject to, governed by, and interpreted in accordance with, the laws of the State of Iowa.

5. **Severability.** Should any provision of this Agreement be declared or be determined by any court to be illegal or invalid, the validity of the remaining parts, terms, or provisions shall not be affected thereby and said illegal or invalid part, term, or provision shall be deemed not to be a part of this Agreement.

6. **Entire Agreement.** This Agreement sets forth the entire agreement between the Parties hereto and fully supersedes any and all prior agreements or understanding between the Parties hereto pertaining to the subject matter hereof.

7. **Counterparts.** This Agreement shall be executed in one or more counterparts and by facsimile or other electronic means, each counterpart shall, for all purposes, be deemed an original, and all counterparts shall constitute the same instrument.

8. **Authority to Sign.** The undersigned individuals represent and warrant that they have authority to execute the Agreement on behalf of their respective parties. The undersigned individuals represent and warrant that all necessary corporate actions or resolutions have been taken to authorize the execution of this Agreement.

9. **Drafting.** This Agreement was negotiated at arm's-length and entered into freely by the Parties, who have had opportunity to seek the advice of counsel. In the event an ambiguity exists in any provision of this Agreement, such ambiguity is not to be construed by reference to any doctrine or statute calling for ambiguities to be construed against the drafter of the document.

10. **Captions.** The captions or headings of the sections in this Agreement are for the convenience of reference only and in no way define, limit, or affect the scope or substance of any section of this Agreement.

11. **Scope of Promises, Representations, and Inducements.** Parties acknowledge, warrant and represent that no promises, representation or inducements, except as herein set forth, have been offered or made by a party hereto or to any other party hereto to secure the execution of any provision of this Agreement.

12. **Successors and Assigns.** This Agreement shall be binding upon and inure to the benefit of each Party's successors and assigns.

13. **Modifications.** No part or provision of this Agreement may be changed, modified, waived, discharged or terminated except by an instrument in writing signed by the Party against whom enforcement of such change, modification, waiver, discharge or termination is sought. The failure of a party to seek redress for violation of, or to insist upon strict performance of, any provision of this Agreement shall not be a waiver of that provision by the party to estop that party from asserting fully any and all of its rights under this Agreement.

14. **Further Assurances.** Each party shall execute such other and further documents, and take such other and further actions as may be reasonably requested by a Party hereto for the purpose effectuating the agreements herein.

IN WITNESS WHEREOF, the Parties hereto have executed this Social Services Funding Agreement effective on the last date set forth below.

MONTICELLO FIREFIGHTER'S ORGANIZATION, Provider

By: _____

Date of Signature: _____

City of Monticello, Iowa

By: _____

Jake Ellwood, Mayor

Date of Signature: _____

City Council Meeting
 Prep. Date: 4/2/2026
 Preparer: Sally Hinrichsen



Agenda Item: # 7
 Agenda Date: 4/6/2026

Communication Page

Agenda Items Description: Resolution Approving Jones County JETS Transportation System investment and agreement for FY '27 in the amount of \$1,500.00

Type of Action Requested: Motion; **Resolution**; Ordinance; Report; Public Hearing; Closed Session

Attachments & Enclosures:

| |
|---------------------|
| Proposed Resolution |
| Agreement |
| |

Fiscal Impact:

| | |
|-------------------|-----------------------|
| Budget Line Item: | |
| Budget Summary: | Admin County Contrib. |
| Expenditure: | \$1,500 |
| Revenue: | |

Synopsis: Jones County JETS Transportation System request City financial support for FY 2027.

Background Information: Iowa Auditor of State has provided guidance regarding the Iowa Constitution Article III, Section 31 and guidance for the City to give funds to private entities and the importance to identify and ensure the funds are serving a public purpose. No public money or property shall be appropriated for local, or private purpose, unless such appropriation, compensation, or claim, be allowed by two thirds of the members elected. It is a requirement that public funds be spent for the public benefit and/or purpose. Council should determine their finding of the “Public Purpose”. An Agreement, with the private entity, setting out the facts and rationale for how the public will benefit from the transfer of public funds to the private entity. The agreement should be approved by resolution of the Council

The City has regularly supported the JETS program and the JETS program serves many Monticello residents. The amount requested \$1,500 is consistent with the City’s investment since FY ‘10.

Staff believes JETS to be a worthwhile and necessary service for Monticello. We did not pursue information related to the contributions of other Jones County municipalities; it is clearly a service used regularly by Monticello residents.

Recommendation: Recommendation that the Council take appropriate action on the Jones County JETS request for funding.

City of Monticello, Iowa

RESOLUTION

Approving Jones County JETS Transportation System investment and agreement for FY '27 in the amount of \$1,500.00

WHEREAS, the City of Monticello, Iowa is an incorporated City within Jones County, Iowa, and

WHEREAS, Jones County JETS Transportation System has requested an investment in their system from the City of Monticello, and

WHEREAS, the Monticello City Council reviewed agreement with Jones County JETS Transportation System to support the JETS Transportation System, and

WHEREAS, the Agreement with the above entity is subject to renewal annually, with the agreement for FY '27 being presented for approval in the amount of \$1,500.00, and

WHEREAS, The Monticello City Council has considered the request made by Jones County JETS Transportation System, and has determined it appropriate to invest in Jones County JETS Transportation System, and

NOW THEREFORE BE IT RESOLVED by the City of Monticello, through its' City Council, in session this 6th day of April, 2026 that the City of Monticello does hereby approve the agreement with Jones County JETS Transportation System, previously mentioned herein, and does hereby authorize the Mayor to execute the same on behalf of the City Council.

IN TESTIMONY WHEREOF, I have hereunto subscribed my name and caused the Great Seal of the City of Monticello, Iowa to be affixed hereto. Done this 6th day of April, 2026.

Jake Ellwood, Mayor

Attest:

Sally Hinrichsen, City Clerk/Treasurer

**CITY OF MONTICELLO AND JONES
COUNTY JETS SOCIAL SERVICES
FUNDING AGREEMENT FOR NON-PROFIT
ORGANIZATIONS**

This Social Services Funding Agreement (“Agreement”) is entered into by and between the Jones County jets (hereinafter referred to as “Provider” which expression shall include its agents, successors or assigns) and the City of Monticello, Iowa (hereinafter “the City”). Provider and the City are collectively referred to as “the Parties.”

I. RECITALS

A. The City of Monticello, Iowa is committed to protecting and preserving the health, safety and welfare of its residents.

B. The City finds that providing funding for certain charitable and not-for-profit enterprises which directly serve and benefit the residents of Monticello is an effective and efficient means to those ends, particularly in regard to underserved portions of the population.

C. Provider is a charitable or not-for-profit organization which offers the following services benefiting residents of Monticello (the “Services”):

JETS provides transportation for the public to work, doctor appointments, shopping, etc. The system is especially committed to transporting the elderly, those in wheelchairs, and those with physical or mental disabilities. However, the service is open to all residents in Jones County.

D. The City finds that the Services offered by Provider serve an important public purpose to help promote the health, safety and welfare of residents of Monticello.

E. Provider has asked the City for financial assistance which will allow the Provider to offer the Services to City residents in the coming fiscal year. The City finds that a payment to Provider to help ensure its ongoing operations is a reasonable and appropriate use of public funds.

II. TERMS

1. **Recitals.** By this reference, the Recitals set forth above are incorporated into and made part of this Agreement.

2. **Consideration.** Upon execution of this Agreement by all Parties and upon approval of the Agreement by the City’s council, the City shall pay Provider the sum of \$1,500 (One Thousand Five Hundred). In return, Provider agrees to provide the Services to residents of Monticello as part of its ongoing operations. Funds will be paid after expenditures have been

made by the Provider. If the Provider can show a hardship from the payment being made after the expenses have been incurred, the City will consider a payment immediately prior to the expense being made, if proof of the expense is provided.

3. **Accounting.** Provider agrees to allocate said funds in accordance with its operational goals to provide the Services to area residents, including residents of Monticello, and to provide an annual accounting to the City showing that the funds were so applied. Annual accounting will include a summary of funds received and spent and receipts totally at least the total amount contributed by the City.

4. **Interpretation.** The language of all parts of this Agreement shall in all cases be construed as a whole, according to its fair meaning, and not strictly for or against any of the Parties. This Agreement is made and entered into, and shall be subject to, governed by, and interpreted in accordance with, the laws of the State of Iowa.

5. **Severability.** Should any provision of this Agreement be declared or be determined by any court to be illegal or invalid, the validity of the remaining parts, terms, or provisions shall not be affected thereby and said illegal or invalid part, term, or provision shall be deemed not to be a part of this Agreement.

6. **Entire Agreement.** This Agreement sets forth the entire agreement between the Parties hereto and fully supersedes any and all prior agreements or understanding between the Parties hereto pertaining to the subject matter hereof.

7. **Counterparts.** This Agreement shall be executed in one or more counterparts and by facsimile or other electronic means, each counterpart shall, for all purposes, be deemed an original, and all counterparts shall constitute the same instrument.

8. **Authority to Sign.** The undersigned individuals represent and warrant that they have authority to execute the Agreement on behalf of their respective parties. The undersigned individuals represent and warrant that all necessary corporate actions or resolutions have been taken to authorize the execution of this Agreement.

9. **Drafting.** This Agreement was negotiated at arm's-length and entered into freely by the Parties, who have had opportunity to seek the advice of counsel. In the event an ambiguity exists in any provision of this Agreement, such ambiguity is not to be construed by reference to any doctrine or statute calling for ambiguities to be construed against the drafter of the document.

10. **Captions.** The captions or headings of the sections in this Agreement are for the convenience of reference only and in no way define, limit, or affect the scope or substance of any section of this Agreement.

11. **Scope of Promises, Representations, and Inducements.** Parties acknowledge, warrant and represent that no promises, representation or inducements, except as herein set forth, have been offered or made by a party hereto or to any other party hereto to secure the execution of any provision of this Agreement.

12. **Successors and Assigns.** This Agreement shall be binding upon and inure to the benefit of each Party's successors and assigns.

13. **Modifications.** No part or provision of this Agreement may be changed, modified, waived, discharged or terminated except by an instrument in writing signed by the Party against whom enforcement of such change, modification, waiver, discharge or termination is sought. The failure of a party to seek redress for violation of, or to insist upon strict performance of, any provision of this Agreement shall not be a waiver of that provision by the party to estop that party from asserting fully any and all of its rights under this Agreement.

14. **Further Assurances.** Each party shall execute such other and further documents, and take such other and further actions as may be reasonably requested by a Party hereto for the purpose effectuating the agreements herein.

IN WITNESS WHEREOF, the Parties hereto have executed this Social Services Funding Agreement effective on the last date set forth below.

JONES COUNTY JETS, Provider

By: _____

Date of Signature: _____

City of Monticello, Iowa

By: _____

Jake Ellwood, Mayor

Date of Signature: _____

City Council Meeting
Prep. Date: 4/2/2026
Preparer: Sally Hinrichsen



Agenda Item: # 8
Agenda Date: 4/6/2026

Communication Page

Agenda Items Description: Resolution Approving Jones County Senior Dining Funding Investment and agreement for FY '27 in the amount of \$4,495.00

Type of Action Requested: Motion; **Resolution**; Ordinance; Report; Public Hearing; Closed Session

Attachments & Enclosures:

Proposed Resolution

Agreement

Fiscal Impact:

Budget Line Item:

Budget Summary:

Expenditure:

Revenue:

Admin contribution

\$4,495.00

Synopsis: Request of Senior Dining program for annual appropriation.

Background Information: Iowa Auditor of State has provided guidance regarding the Iowa Constitution Article III, Section 31 and guidance for the City to give funds to private entities and the importance to identify and ensure the funds are serving a public purpose. No public money or property shall be appropriated for local, or private purpose, unless such appropriation, compensation, or claim, be allowed by two thirds of the members elected. It is a requirement that public funds be spent for the public benefit and/or purpose. Council should determine their finding of the “Public Purpose”. An Agreement, with the private entity, setting out the facts and rationale for how the public will benefit from the transfer of public funds to the private entity. The agreement should be approved by resolution of the Council

The City of Monticello has been appropriating funds to senior dining for a number of years. The requested investment is based on the number of meals served in Monticello last year and is based on a percentage of what the Senior Dining Program need to provide services the seniors,

Paid \$4,838 in FY 26; \$4,745 in FY '25; \$4,329 in FY '24; \$3,600 in FY '23; \$3,200 in FY '22; \$5,025 in FY '21; and \$3,700 in FY '20

Recommendation: Recommendation that the Council take appropriate action on the Jones County Senior Dining request for funding.

City of Monticello, Iowa

RESOLUTION

Approving Jones County Senior Dining Investment and agreement for FY '27 in the amount of \$4,495.00

WHEREAS, Monticello has historically supported the Senior Dining program in Monticello, typically being based upon a per meal rate or a % of program use, and

WHEREAS, Jones County Senior Dining has requested \$4,495.00 as the City of Monticello FY '27 investment is based on the number of meals served in Monticello last fiscal year and is based on a percentage of what the Senior Dining Program needs to provide services for the seniors, up from \$4,838 in FY'26, \$4,75 in FY '25, \$4,329 in FY '24, and \$3,600 in FY '23, and

WHEREAS, the Monticello City Council reviewed agreement with Jones County Senior Dining to support the County Senior Dining Program, and

WHEREAS, the Agreement with the above entity is subject to renewal annually, with the agreement for FY '27 being presented for approval in the amount of \$4,495.00, and

WHEREAS, the Monticello City Council has considered the request made by Jones County Senior Dining, and has determined it appropriate to invest in the Senior Dining Program, and.

NOW THEREFORE BE IT RESOLVED by the City of Monticello, through its' City Council, in session this 6th day of April, 2026 that the City of Monticello does hereby approve the agreement with Jones County Senior Dining, previously mentioned herein, and does hereby authorize the Mayor to execute the same on behalf of the City Council.

IN TESTIMONY WHEREOF, I have hereunto subscribed my name and caused the Great Seal of the City of Monticello, Iowa to be affixed hereto. Done this 6th day of April, 2026.

Jake Ellwood, Mayor

Attest:

Sally Hinrichsen, City Clerk/Treasurer

**CITY OF MONTICELLO AND JONES
COUNTY SENIOR DINING SOCIAL
SERVICES FUNDING AGREEMENT FOR
NON-PROFIT ORGANIZATIONS**

This Social Services Funding Agreement (“Agreement”) is entered into by and between the Jones County Senior Dining (hereinafter referred to as “Provider” which expression shall include its agents, successors or assigns) and the City of Monticello, Iowa (hereinafter “the City”). Provider and the City are collectively referred to as “the Parties.”

I. RECITALS

A. The City of Monticello, Iowa is committed to protecting and preserving the health, safety and welfare of its residents.

B. The City finds that providing funding for certain charitable and not-for-profit enterprises which directly serve and benefit the residents of Monticello is an effective and efficient means to those ends, particularly in regard to underserved portions of the population.

C. Provider is a charitable or not-for-profit organization which offers the following services benefiting residents of Monticello (the “Services”):

The Provider provides meals for Seniors in Monticello and the rest of Jones County. They provide dining rooms in Monticello, Anamosa and Wyoming. The operation of the Jones County Senior Center benefits seniors throughout the County. Seniors receive nutritious noon meals in addition to the opportunity for socialization and education. Frail homebound seniors in the county receive nutritious meals delivered to their homes and are monitored on a regular basis. The goal is that every senior in Jones County has a safe and healthy meal so that they can thrive.

D. The City finds that the Services offered by Provider serve an important public purpose for providing Seniors with nutritious noon meals in addition to the opportunity for socialization and education, while promoting the health, safety and welfare of senior residents of Monticello.

E. Provider has asked the City for financial assistance which will allow the Provider to offer the Services to City residents in the coming fiscal year. The City finds that a payment to Provider to help ensure its ongoing operations is a reasonable and appropriate use of public funds.

II. TERMS

1. **Recitals.** By this reference, the Recitals set forth above are incorporated into and made part of this Agreement.

2. **Consideration.** Upon execution of this Agreement by all Parties and upon approval of the Agreement by the City's council, the City shall pay Provider the sum of \$4,495 (Four Thousand Four Hundred Ninety-Five). In return, Provider agrees to provide the Services to residents of Monticello as part of its ongoing operations. Funds will be paid after expenditures have been made by the Provider. If the Provider can show a hardship from the payment being made after the expenses have been incurred, the City will consider a payment immediately prior to the expense being made, if proof of the expense is provided. If the provider fails to serve 4,500 meals in Monticello, they agree to pay the City back \$.50 for each meal under 4,500 meals served, not to exceed the \$3,000.

3. **Accounting.** Provider agrees to allocate said funds in accordance with its operational goals to provide the Services to area residents, including residents of Monticello, and to provide an annual accounting to the City showing that the funds were so applied. Annual accounting will include a summary of funds received and spent and receipts totally at least the total amount contributed by the City.

4. **Interpretation.** The language of all parts of this Agreement shall in all cases be construed as a whole, according to its fair meaning, and not strictly for or against any of the Parties. This Agreement is made and entered into, and shall be subject to, governed by, and interpreted in accordance with, the laws of the State of Iowa.

5. **Severability.** Should any provision of this Agreement be declared or be determined by any court to be illegal or invalid, the validity of the remaining parts, terms, or provisions shall not be affected thereby and said illegal or invalid part, term, or provision shall be deemed not to be a part of this Agreement.

6. **Entire Agreement.** This Agreement sets forth the entire agreement between the Parties hereto and fully supersedes any and all prior agreements or understanding between the Parties hereto pertaining to the subject matter hereof.

7. **Counterparts.** This Agreement shall be executed in one or more counterparts and by facsimile or other electronic means, each counterpart shall, for all purposes, be deemed an original, and all counterparts shall constitute the same instrument.

8. **Authority to Sign.** The undersigned individuals represent and warrant that they have authority to execute the Agreement on behalf of their respective parties. The undersigned individuals represent and warrant that all necessary corporate actions or resolutions have been taken to authorize the execution of this Agreement.

9. **Drafting.** This Agreement was negotiated at arm's-length and entered into freely by the Parties, who have had opportunity to seek the advice of counsel. In the event an ambiguity exists in any provision of this Agreement, such ambiguity is not to be construed by reference to

any doctrine or statute calling for ambiguities to be construed against the drafter of the document.

10. **Captions.** The captions or headings of the sections in this Agreement are for the convenience of reference only and in no way define, limit, or affect the scope or substance of any section of this Agreement.

11. **Scope of Promises, Representations, and Inducements.** Parties acknowledge, warrant and represent that no promises, representation or inducements, except as herein set forth, have been offered or made by a party hereto or to any other party hereto to secure the execution of any provision of this Agreement.

12. **Successors and Assigns.** This Agreement shall be binding upon and inure to the benefit of each Party's successors and assigns.

13. **Modifications.** No part or provision of this Agreement may be changed, modified, waived, discharged or terminated except by an instrument in writing signed by the Party against whom enforcement of such change, modification, waiver, discharge or termination is sought. The failure of a party to seek redress for violation of, or to insist upon strict performance of, any provision of this Agreement shall not be a waiver of that provision by the party to estop that party from asserting fully any and all of its rights under this Agreement.

14. **Further Assurances.** Each party shall execute such other and further documents, and take such other and further actions as may be reasonably requested by a Party hereto for the purpose effectuating the agreements herein.

IN WITNESS WHEREOF, the Parties hereto have executed this Social Services Funding Agreement effective on the last date set forth below.

JONES COUNTY SENIOR DINING, Provider

By: _____

Date of Signature: _____

City of Monticello, Iowa

By: _____

Jake Ellwood, Mayor

Date of Signature: _____

City Council Meeting
Prep. Date: 4/2/2026
Preparer: Sally Hinrichsen



Agenda Item: # 9
Agenda Date: 4/6/2026

Communication Page

Agenda Items Description: Resolution Approving Jones County Tourism Investment and Agreement for FY '27 in the amount of \$1,212.00, plus 4% of Hotel/Motel taxes received by the City of Monticello in FY '25

Type of Action Requested: Motion; **Resolution**; Ordinance; Report; Public Hearing; Closed Session

Attachments & Enclosures:

| |
|---------------------|
| Proposed Resolution |
| Agreement |
| |

Fiscal Impact:

| | |
|-------------------|----------------------------|
| Budget Line Item: | |
| Budget Summary: | Hotel/motel contribution |
| Expenditure: | \$1,212.00 plus 4%of hotel |
| Revenue: | |

Synopsis: Tourism requests continued investment from the City.

Background Information: Iowa Auditor of State has provided guidance regarding the Iowa Constitution Article III, Section 31 and guidance for the City to give funds to private entities and the importance to identify and ensure the funds are serving a public purpose. No public money or property shall be appropriated for local, or private purpose, unless such appropriation, compensation, or claim, be allowed by two thirds of the members elected. It is a requirement that public funds be spent for the public benefit and/or purpose. Council should determine their finding of the “Public Purpose”. An Agreement, with the private entity, setting out the facts and rationale for how the public will benefit from the transfer of public funds to the private entity. The agreement should be approved by resolution of the Council

When Jones County Tourism request was received prior to the FY '24 request, the Council did not award any portion of the Hotel/Motel Tax, instead suggesting that requests for Hotel/Motel tax support should be supported by specific projects/efforts, not just in the General Fund.

The City of Monticello has been a fairly consistent member of Jones County tourism donating \$1,139 per year since at least FY '13 (\$.30 per capita) The Tourism Board has requested a continuation of the \$.30 per capita investment plus 4% of the City Hotel/Motel tax receipts. With the new census count the amount raised to \$1,212.00, for FY '27. The investment request for FY '27, the continuation of the \$.30 per capita investment would be \$1,212 and the Hotel/Motel taxes collected by the City in FY 2024 was \$44,320.88 at 4% equals \$1,772.84; for a total of \$2,984.84 This investment would be paid from the General fund this year, like FY '26.

Staff Recommendation: Recommendation that the Council take appropriate action on the Jones County Tourism request for funding and adding amount of Hotel/Motel Tax, if desired.

CITY OF MONTICELLO, IOWA

RESOLUTION

Approving Jones County Tourism Investment and Agreement for FY '27 in the amount of \$1,212.00, plus 4% of the Monticello Hotel/Motel tax

WHEREAS, Jones County Tourism has requested an investment in their Organization from the City of Monticello, and

WHEREAS, the Monticello City Council has considered the request made by Jones County Tourism, and has determined it appropriate to invest in Jones County Tourism, by way of an investment in the amount of \$1,212.00 for FY 2027, same representing a \$.30 cent per capita investment, plus \$1,478.74, which is 4% of the Monticello Hotel/Motel Taxes collected in FY 2025 for a total of \$2,690.74 and

WHEREAS, the Monticello City Council reviewed agreement with Jones County Tourism to support tourism in Jones County, and

WHEREAS, the Agreement with the above entity is subject to renewal annually, with the agreement for FY '27 being approved in the amount of \$1,212.00 for FY 2027, same representing a \$.30 cent per capita investment, plus 4% of the Monticello Hotel/Motel Tax collected in FY 2025, and

WHEREAS, the Monticello City Council has considered the request made by Jones County Tourism, and has determined it appropriate to invest in tourism in Jones County, and.

NOW THEREFORE BE IT RESOLVED by the City of Monticello, through its' City Council, in session this 6th day of April, 2026 that the City of Monticello does hereby approve the agreement with Jones County Tourism, previously mentioned herein, and does hereby authorize the Mayor to execute the same on behalf of the City Council. City of Monticello shall budget for and invest in Jones County Tourism in the amount of \$1,212.00 for FY 2027, same representing a \$.30 cent per capita investment, plus 4% of the Monticello Hotel/Motel Tax collected in FY 2025, which is \$1,478.74 for a total of \$2,690.74.

IN TESTIMONY WHEREOF, I have hereunto subscribed my name and caused the Great Seal for the City of Monticello, Iowa to be affixed. Done this 6th day of April, 2026.

Jake Ellwood, Mayor

Attest:

Sally Hinrichsen, City Clerk/Treasurer

**CITY OF MONTICELLO AND JONES
TOURISM SOCIAL SERVICES FUNDING
AGREEMENT FOR NON-PROFIT
ORGANIZATIONS**

This Social Services Funding Agreement (“Agreement”) is entered into by and between the Jones County Tourism (hereinafter referred to as “Provider” which expression shall include its agents, successors or assigns) and the City of Monticello, Iowa (hereinafter “the City”). Provider and the City are collectively referred to as “the Parties.”

I. RECITALS

A. The City of Monticello, Iowa is committed to protecting and preserving the health, safety and welfare of its residents.

B. The City finds that providing funding for certain charitable and not-for-profit enterprises which directly serve and benefit the residents of Monticello is an effective and efficient means to those ends, particularly in regard to underserved portions of the population.

C. Provider is a not-for-profit 501c6 organization which offers the following services benefiting residents of Monticello (the “Services”): Highlighting the Communities resources, parks, historical landmarks, Selective Marketing based off Reports from Travel Iowa and the state of Iowa, working with local businesses, customized travel itinerary with Monticello attractions and retailers, Influencer Recommendations and media posts to represent Monticello, organizations and locals within Monticello to Grow and Promote Monticello based off Current Trends/Reports on Social Media Platforms, Reaching a Different Demographic of people while also reaching those in Jones County and letting them know what Monticello offers and has, in hopes that locals stay local instead of traveling, utilizing services, resources or shopping elsewhere.

The Provider engages communities in efforts to promote and market Monticello as a tourist destination, with Monticello’s historic district, the Maquoketa River for canoeing and kayaking, many special events and wonderful array of specialty shops in Jones County. The goal is that Provider shall attract visitors to the Community for the betterment of the residents of Monticello.

D. The City finds that the Services offered by Provider serve an important public purpose for promoting and marketing Monticello to visitors to spend time in the community for the betterment of residents of Monticello.

E. Provider has asked the City for financial assistance which will allow the Provider to offer the Services to City residents in the coming fiscal year. The City finds that a payment to Provider to help ensure its ongoing operations is a reasonable and appropriate use of public funds.

II. TERMS

1. **Recitals.** By this reference, the Recitals set forth above are incorporated into and made part of this Agreement.

2. **Consideration.** Upon execution of this Agreement by all Parties and upon approval of the Agreement by the City's council, the City shall pay Provider the sum of \$1,212.00 for FY 2027, same representing a \$.30 cent per capita investment, plus 4% of the Monticello Hotel/Motel Taxes collected in FY 2025, which is \$1,478.74. In return, Provider agrees to provide the Services to residents of Monticello as part of its ongoing operations. Funds will be paid after expenditures have been made by the Provider. If the Provider can show a hardship from the payment being made after the expenses have been incurred, the City will consider a payment immediately prior to the expense being made, if proof of the expense is provided.

3. **Accounting.** Provider agrees to allocate said funds in accordance with its operational goals to provide the Services to area residents, including residents of Monticello, and to provide an annual accounting to the City showing that the funds were so applied. Annual accounting will include a summary of funds received and spent and receipts totally at least the total amount contributed by the City.

4. **Interpretation.** The language of all parts of this Agreement shall in all cases be construed as a whole, according to its fair meaning, and not strictly for or against any of the Parties. This Agreement is made and entered into, and shall be subject to, governed by, and interpreted in accordance with, the laws of the State of Iowa.

5. **Severability.** Should any provision of this Agreement be declared or be determined by any court to be illegal or invalid, the validity of the remaining parts, terms, or provisions shall not be affected thereby and said illegal or invalid part, term, or provision shall be deemed not to be a part of this Agreement.

6. **Entire Agreement.** This Agreement sets forth the entire agreement between the Parties hereto and fully supersedes any and all prior agreements or understanding between the Parties hereto pertaining to the subject matter hereof.

7. **Counterparts.** This Agreement shall be executed in one or more counterparts and by facsimile or other electronic means, each counterpart shall, for all purposes, be deemed an original, and all counterparts shall constitute the same instrument.

8. **Authority to Sign.** The undersigned individuals represent and warrant that they have authority to execute the Agreement on behalf of their respective parties. The undersigned individuals represent and warrant that all necessary corporate actions or resolutions have been taken to authorize the execution of this Agreement.

9. **Drafting.** This Agreement was negotiated at arm's-length and entered into freely by the Parties, who have had opportunity to seek the advice of counsel. In the event an ambiguity exists in any provision of this Agreement, such ambiguity is not to be construed by reference to any doctrine or statute calling for ambiguities to be construed against the drafter of the document.

10. **Captions.** The captions or headings of the sections in this Agreement are for the convenience of reference only and in no way define, limit, or affect the scope or substance of any section of this Agreement.

11. **Scope of Promises, Representations, and Inducements.** Parties acknowledge, warrant and represent that no promises, representation or inducements, except as herein set forth, have been offered or made by a party hereto or to any other party hereto to secure the execution of any provision of this Agreement.

12. **Successors and Assigns.** This Agreement shall be binding upon and inure to the benefit of each Party's successors and assigns.

13. **Modifications.** No part or provision of this Agreement may be changed, modified, waived, discharged or terminated except by an instrument in writing signed by the Party against whom enforcement of such change, modification, waiver, discharge or termination is sought. The failure of a party to seek redress for violation of, or to insist upon strict performance of, any provision of this Agreement shall not be a waiver of that provision by the party to estop that party from asserting fully any and all of its rights under this Agreement.

14. **Further Assurances.** Each party shall execute such other and further documents, and take such other and further actions as may be reasonably requested by a Party hereto for the purpose effectuating the agreements herein.

IN WITNESS WHEREOF, the Parties hereto have executed this Social Services Funding Agreement effective on the last date set forth below.

JONES COUNTY TOURISM, Provider

By: _____

Date of Signature: _____

City of Monticello, Iowa

By: _____
 Jake Ellwood, Mayor

Date of Signature: _____

City Council Meeting
Prep. Date: 4/2/2026
Preparer: Sally Hinrichsen



Agenda Item: # 10
Agenda Date: 4/6/2026

Communication Page

Agenda Items Description: **Resolution** Appropriating funds necessary to meet the City’s Obligation to Monticello Main Street Iowa Program Agreement

| | |
|--|---|
| Type of Action Requested: Resolution | |
| Attachments & Enclosures: Resolution Agreement | Fiscal Impact: Budget Line Item: Budget Summary: Expenditure: Revenue: |

Synopsis: Monticello Main Street representatives were present at the March 23th City Council meeting to made a presentation on their progress with the new Main Street program. Additionally, they are asking for approval of appropriation for FY ‘27 funding.

Background: In late 2021, representatives from Monticello began preparing an application to the State of Iowa, Iowa Economic Development Agency (IEDA), and Main Street Iowa to become a Main Street community. In April, 2022, the City Council authorized the application to become a Main Street community and a pledge to fund the program in the amount of \$40,000 for the first three years.

The total budget for the operation of the Monticello Main Street program is \$120,000 per year. Of that, generally, one third of the revenues should come from private fundraising and community support, one third from the benefitted business community and stakeholders, and one third from the local government. Per the Agreement, the City’s funding is a dollar-for-dollar match to the private fundraising, not to exceed \$40,000, for 3 years.

For City budget purposes, a portion of that pledge amount would be generated by the Hotel/Motel fund annually, and the other portion is drawn from the General Fund. The hotel/motel tax generates over \$20,000 per year, and is growing. The Hotel/Motel fund and historically has been used to fund the JCEDC, Chamber, and a portion of Monticello Main Street.

Recommendation: Approval is recommended.

City of Monticello, Iowa

RESOLUTION

Approving Monticello Main Street Investment agreement for FY '27 in the amount of \$40,000.00

WHEREAS, the City of Monticello, Iowa is an incorporated City within Jones County, Iowa, and

WHEREAS, the City of Monticello has partnered with the Monticello Main Street for a number of years. The annual investment amount requested by is \$40,000.00, and

WHEREAS, the Council finds that the relationship by and between Monticello Main Street and the City of Monticello is mutually beneficial and that the City should continue to invest in Monticello Main Street, and

WHEREAS, the Monticello City Council reviewed agreement with Monticello Main Street to support Monticello Main Street, and

WHEREAS, the Agreement with the above entity is subject to renewal annually, with the agreement for FY '27 being presented for approval in the amount of \$40,000.00, and

WHEREAS, the Monticello City Council has considered the request made by Monticello Main Street, and has determined it appropriate to invest in the Monticello Main Street.

NOW THEREFORE BE IT RESOLVED by the City of Monticello, through its' City Council, in session this 6th day of April, 2026 that the City of Monticello does hereby approve the agreement with Monticello Main Street, previously mentioned herein, and does hereby authorize the Mayor to execute the same on behalf of the City Council.

IN TESTIMONY WHEREOF, I have hereunto subscribed my name and caused the Great Seal of the City of Monticello, Iowa to be affixed hereto.
Done this 6th day of April, 2026.

Jake Ellwood, Mayor

Attest:

Sally Hinrichsen, City Clerk/Treasurer

**CITY OF MONTICELLO AND MONTICELLO
MAIN STREET SERVICES FUNDING
AGREEMENT FOR NON-PROFIT
ORGANIZATIONS**

This Services Funding Agreement (“Agreement”) is entered into by and between the Monticello Main Street (hereinafter referred to as “Provider” which expression shall include its agents, successors or assigns) and the City of Monticello, Iowa (hereinafter “the City”). Provider and the City are collectively referred to as “the Parties.”

I. RECITALS

A. The City of Monticello, Iowa is committed to protecting and preserving the health, safety and welfare of its residents, and providing for economic development, downtown revitalization, and tourism for the economic benefit of the City.

B. The City finds that providing funding for certain not-for-profit enterprises which directly serve and benefit the residents and property owners of Monticello is an effective and efficient means to those ends, particularly in regard to the revitalization of the central business district.

C. Provider is a not-for-profit organization which offers the following services benefiting residents and property owners of Monticello, particularly those within the Main Street district (the “Services”):

1. Maintain Monticello Main Street program's focus on the revitalization of the designated Main Street district utilizing the Main Street Approach®. This focus should be reflected in the programs annual plan of action, goals and objectives, vision, and mission statement.
2. Promote the revitalization of the Main Street district through advocacy of tools and resources that support district investment, for example: development incentives, ordinances and policy that promote the revitalization of the district, design guidelines or standards that promote the protection of the traditional character of the district, district development planning, etc.
3. Employ a paid part-time Executive Director for the Local Main Street Program who will be responsible for the day-to-day administration of the Local Main Street Program in the City.
4. Maintain an office within the designated boundaries of the local Main Street district.
5. Submit economic impact reports to the City, on or before established due date of the report by Main Street Iowa, which documents the progress of the Local Main Street Program's activities.
6. Maintain Main Street America® National Accreditation.

D. The City finds that the Services offered by Provider serve an important public

purpose for promoting downtown revitalization to the core of the community through the ideals of the Main Street Approach® program.

E. Provider has asked the City for financial assistance which demonstrates City support in accordance with the Main Street® Program and will allow the Provider to offer the Services to City residents from July 1, 2026, to June 30, 2027 (Fiscal Year 2027). The City finds that a payment to Provider to help ensure its ongoing operations is a reasonable and appropriate use of public funds.

II. TERMS

1. **Recitals.** By this reference, the Recitals set forth above are incorporated into and made part of this Agreement.

2. **Consideration.** Upon execution of this Agreement by all Parties and upon approval of the Agreement by the City's council, the City shall pay Provider the sum of \$40,000 (Forty Thousand Dollars). In return, Provider agrees to provide the Services to residents and property owners of Monticello as part of its ongoing operations. If the provider fails to meet the obligations of the Main Street Approach® program, the Provider agrees to refund the City \$769.00 (Seven Hundred Sixty-Nine dollars) per week of non-compliance, not to exceed the original amount funded during the term of the Agreement.

3. **Accounting.** Provider agrees to allocate said funds in accordance with its operational goals to provide the Services to area residents, including residents and property owners of Monticello, and to provide an annual accounting to the City showing that the funds were so applied. Annual accounting will include a summary of funds received and spent and receipts totaling at least three times the total amount contributed by the City.

4. **Interpretation.** The language of all parts of this Agreement shall in all cases be construed as a whole, according to its fair meaning, and not strictly for or against any of the Parties. This Agreement is made and entered into, and shall be subject to, governed by, and interpreted in accordance with, the laws of the State of Iowa.

5. **Severability.** Should any provision of this Agreement be declared or be determined by any court to be illegal or invalid, the validity of the remaining parts, terms, or provisions shall not be affected thereby and said illegal or invalid part, term, or provision shall be deemed not to be a part of this Agreement.

6. **Entire Agreement.** This Agreement sets forth the entire agreement between the Parties hereto and fully supersedes any and all prior agreements or understanding between the Parties hereto pertaining to the subject matter hereof.

7. **Term.** This Agreement shall be in full force and effect on July 1, 2026, and shall

extend through June 30, 2027.

8. **Counterparts.** This Agreement shall be executed in one or more counterparts and by facsimile or other electronic means, each counterpart shall, for all purposes, be deemed an original, and all counterparts shall constitute the same instrument.

9. **Authority to Sign.** The undersigned individuals represent and warrant that they have authority to execute the Agreement on behalf of their respective parties. The undersigned individuals represent and warrant that all necessary corporate actions or resolutions have been taken to authorize the execution of this Agreement.

10. **Drafting.** This Agreement was negotiated at arm's-length and entered into freely by the Parties, who have had opportunity to seek the advice of counsel. In the event an ambiguity exists in any provision of this Agreement, such ambiguity is not to be construed by reference to any doctrine or statute calling for ambiguities to be construed against the drafter of the document.

11. **Captions.** The captions or headings of the sections in this Agreement are for the convenience of reference only and in no way define, limit, or affect the scope or substance of any section of this Agreement.

12. **Scope of Promises, Representations, and Inducements.** Parties acknowledge, warrant and represent that no promises, representation or inducements, except as herein set forth, have been offered or made by a party hereto or to any other party hereto to secure the execution of any provision of this Agreement.

13. **Successors and Assigns.** This Agreement shall be binding upon and inure to the benefit of each Party's successors and assigns.

14. **Modifications.** No part or provision of this Agreement may be changed, modified, waived, discharged or terminated except by an instrument in writing signed by the Party against whom enforcement of such change, modification, waiver, discharge or termination is sought. The failure of a party to seek redress for violation of, or to insist upon strict performance of, any provision of this Agreement shall not be a waiver of that provision by the party to estop that party from asserting fully and all of its rights under this Agreement.

15. **Further Assurances.** Each party shall execute such other and further documents, and take such other and further actions as may be reasonably requested by a Party hereto for the purpose effectuating the agreements herein.

IN WITNESS WHEREOF, the Parties hereto have executed this Social Services Funding Agreement effective on the last date set forth below.

MONTICELLO MAIN STREET, Provider

By: _____

Its: _____

Date of Signature: _____

City of Monticello, Iowa

By: _____

Jake Ellwood, Mayor

Date of Signature: _____

City Council Meeting
Prep. Date: 4/1/26
Preparer: Jacob Oswald



Agenda Item: # 11
Agenda Date: 04/6/2026

Communication Page

Agenda Items Description: Resolution to approve City and School Agreement for 2026

Type of Action Requested: Motion; Resolution; Ordinance; Report; Public Hearing; Closed Session

Attachments & Enclosures:

| |
|---|
| City of Monticello and the Monticello CSD |
| |
| |

Fiscal Impact:

| | |
|-------------------|--|
| Budget Line Item: | |
| Budget Summary: | |
| Expenditure: | |
| Revenue: | |

Synopsis: Proposed agreement between the City, and School for the duration of the 2026 season.

Background Information: The attached document outlines the current agreement between the City and School for use of ball diamonds on school property. The City shall pay the amount of \$1,000 to the School to offset the costs needed to maintain the facilities. These items would include mowing, weed whipping, fertilizing, liability and insurance. The City will receive an invoice from the School in August when the summer leagues and tournaments have been completed. Payment will come from tournament revenue and/or be split with league expense.

No changes have been made to the agreement. City is requesting use of the field groomer for teams to following practices and games at the high school complex.

Staff Recommendation: To approve 28E agreement with the school.

City of Monticello, Iowa

RESOLUTION

Approving 28E Agreement between Monticello Community Schools and
City of Monticello use of School Owned Property and Facilities

WHEREAS, The City of Monticello has previously entered into an agreement and relationship associated with youth baseball and softball programming in Monticello, and

WHEREAS, Youth Baseball and Softball, as well as potential adult rec. league baseball and/or softball, plan to utilize various fields and facilities on Monticello Community School District property, and

WHEREAS, The City Park Board have negotiated the terms of an agreement between the City and the School that allows City use and control to a great extent of those fields and facilities needed for the desired programming, with terms related to field maintenance and concession stand operation included, and

WHEREAS, The City Council finds that said agreement is appropriate, in the best interests of the City and should, therefore, be approved.

NOW, THEREFORE, BE IT RESOLVED that the City Council of Monticello, Iowa does hereby approve of the proposed agreement between the City of Monticello and the Monticello Community School District Re: Monticello Youth Baseball and Softball use of School owned Property and Facilities, a copy of same being appended hereto, and authorizes the Mayor to execute the same on behalf of the City Council.

IN TESTIMONY WHEREOF, I have hereunto subscribed my name and caused the Great Seal of the City of Monticello, Iowa to be affixed hereto. Done this 6th day of April, 2026.

Jake Ellwood, Mayor

Attest:

Sally Hinrichsen, City Clerk/Treasurer

**28E Agreement between the
City of Monticello and the Monticello Community School District Re:
Monticello Youth Baseball and Softball Programs**

COMES NOW the City of Monticello, Iowa, a Municipal Corporation (hereinafter “City”) and the Monticello Community School District (hereinafter “School”) do hereby agree to the following terms and conditions related to the use and maintenance of school facilities, related to the Monticello youth baseball and softball programs.

GENERAL PURPOSE:

The purpose of this agreement is to set forth the agreed upon roles and or responsibilities of the City and the School in regard to the planning, operation, oversight and supervision of Monticello youth baseball and softball, from pre-k through 6th grade.

PROPERTIES COVERED:

The following properties, including fields, concession stands as appropriate, related parking areas and other on-site infrastructure, are covered by and subject to the terms and provisions of this agreement.

1. Monticello High School Sport’s Complex (East Field and Prep Diamond only)
2. Two fields located on the grounds of Carpenter Elementary School.
3. Two field located on the grounds of Shannon Elementary School.
4. Lions Field, located on City owned property, near the High School Football Field.

RESPONSIBILITIES:

The parties hereto shall have the following responsibilities:

1. School:
 - a. Shall mow, weed whip/spray, and fertilize and maintain the areas listed above as deemed necessary by the school maintenance staff.
 - b. Shall permit the use, oversight, and management of the properties covered by this agreement.
 - c. Shall cover the cost of electricity and other utilities used in conjunction with permitted uses of said properties.
 - d. Shall ensure the existence of appropriate liability insurance on School owned property.
2. City:
 - a. Shall maintain a master schedule for both practices (rec. league and tournament teams), and Rec. League and Tournament games. Shall manage the scheduling of games including cancellations and rescheduling, and necessary communication with parents, coaches, and umpires as appropriate.
 - i. When scheduling or rescheduling games or practices at the HS sports complex, the City will not schedule on dates of home varsity baseball and/or softball games.
 - ii. A schedule of Rec. League and Tournament games will be provided to the HS Athletic Director and the Director of Buildings and Grounds prior to the start of the season.

- b. Shall ensure the existence of appropriate liability coverage for Rec. League operations and liability coverage on City property. Since the teams are made up of Monticello Residents the school district does not require additional team insurance, however the city will include the following “Hold Harmless Agreement” in the paperwork collected before practice and games begin. The “Hold Harmless Agreement” will need to be signed by the team representative and kept on file with any other documents collected by the City.

HOLD-HARMLESS AGREEMENT

The undersigned, hereafter referred to as “entity,” states that it will hold the Monticello Community School District, hereafter referred to as “school district,” its employees, officers, agents, and/or representatives harmless from any and all damages and claims that may arise in connection with the entity’s use of any facilities and/or equipment owned by the school district whether such damages and claims pertain to the entity itself or its guests. In case any action is brought against the school district or any of its officers, employees or agents, and/or representatives the entity will assume full responsibility for the legal defense thereof, and upon its failure to do so upon proper notice, the school district reserves the right to defend such action and to recover all costs, including attorneys’ fees, from the entity.

- c. Shall pay the amount of \$1000 to the School to offset the costs needed to maintain the facilities. The City will receive an invoice from the School in August when the summer leagues and tournaments have been completed.
- d. Shall be responsible for all field preparation, including general preparation and maintenance for practices, and preparation, including dragging and striping, for games.

Collection and Use of Registration Fees, Concession Revenue, and other Raised Funds:

- 1. The City:
 - a. Shall collect fees; both rec. league registration and tournament team registration fees.
 - b. Shall manage all aspects of concessions operations, including ordering, prepping, staffing, etc. at Shannon Elementary. Revenues generated by the operation of concession stands will be maintained by the City.
 - c. When the City uses the concession stand at the HS Complex they will coordinate this with the HS Athletic Boosters. The City will pay 55% of revenue from concession sales at the HS Complex to the Monticello Athletic Booster Club as reimbursement of concession items. The Monticello Athletic Booster Club may request a higher percentage due to increased costs, if necessary. Items given to umpires and workers will be paid for by the City and those items will also be reimbursed to the HS Athletic Boosters.
 - d. Shall be permitted to sell sponsorships and advertising to be placed on the fencing at the fields. Advertising or promotional materials related to sponsors shall be permitted to be installed on the fencing around the fields so long as it is done in a fashion that

will not damage said fencing and all sponsors are appropriate for a school site. The City shall carefully review all proposed promotional/advertising materials-signage. If found to be acceptable and appropriate by the City, the proposed materials shall be forwarded to the Superintendent of Schools for final approval. Until final approval, no materials shall be displayed on school property. The fees/terms/conditions related to the materials shall be determined by the City and all revenues created by advertising will be retained by the City.

Miscellaneous Terms:

1. Shall get approval from the school superintendent before any improvements to the facilities or property are made. In addition, this work will be coordinated with the Director of Buildings and Grounds, from the school.
2. The equipment owned by the Monticello Community School District (field groomer, pitching machines, Ranger, etc) should not be used by the City for field preparation, practices, or events.
3. Any capital improvements of a permanent, or semi-permanent nature, shall be pre-approved by the school Superintendent. Diamonds on school property include those at Shannon, Carpenter, and the H.S. Sports Complex.
4. The City shall be responsible for the costs of day-to-day repairs to structures, such as concession stands, fencing, scoreboards, sidewalks, batting cages, restrooms, shelters, etc.
5. The City may use the black & white shed at the high school sports complex for storage during the season.
6. The City may use the storage area attached to the concession stand at Shannon Elementary School.
7. The City will receive an invoice from the School in August when the summer leagues and tournaments have been completed.

Term:

The Term of this agreement shall be for one (1) year, commencing April 1, 2026 and ending March 31, 2027. This agreement shall not automatically renew at the conclusion of the term set forth herein but shall be subject to review and approval by the City and the School.

Signed and dated this _____ day of _____, 2026.

City of Monticello, Iowa

Monticello Community School District

Monticello Mayor

Date

School Board President

Date

City Council Meeting
Prep. Date: 4/1/2026
Preparer: Jacob Oswald



Agenda Item: # 12
Agenda Date: 04/6/2026

Communication Page

Agenda Items Description: Resolution Approving the wages for Monticello Aquatic Center and Park and Recreation part-time seasonal staff positions and setting wages

Type of Action Requested: Motion; Resolution; Ordinance; Report; Public Hearing; Closed Session

Attachments & Enclosures:

| |
|--|
| |
| |
| |

Fiscal Impact:

| | |
|-------------------|--|
| Budget Line Item: | |
| Budget Summary: | |
| Expenditure: | |
| Revenue: | |

Synopsis:

Parks and Recreation Department to hire seasonal staff for the upcoming 2026 season.

Background Information:

The Monticello Aquatic Center and Parks and Recreation Department request the hiring of seasonal staff to support daily operations. Aquatic Center staff assist with open swim hours, swim lessons, and special events. Parks staff help with park maintenance, landscaping, facility monitoring, and field preparation. Recreation staff also assist with the operation of concession stands, umpiring and officiating games, and supporting various programs and events.

Staff Recommendation:

To approve hiring of additional part time staff, supported by Park Board.

City of Monticello, Iowa

RESOLUTION

Approving the wages for Monticello Aquatic Center and Park
and Recreation part-time seasonal staff positions and setting wages

WHEREAS, Monticello Aquatic Center hires seasonal staff to assist in the operation of Aquatic Center covering hours of operation, swim lesson instruction, and other various special events, and

WHEREAS, Monticello Park and Recreation desires to hire seasonal staff. Their duties include, but are not limited to, weeding flower beds, weed whipping, removal of trash, cleaning park shelters, water trees/plants/flower beds, public restroom maintenance, monitoring Berndes Center facility and activities and field preparation/maintenance within the City, and

WHEREAS, The City Administrator and Park and Recreation Director recommends hiring part-time seasonal staff, to work under the supervision of the Park and Recreation Director, and

WHEREAS, The Park & Recreation Board recommended the following wages for the part-time seasonal staff:

| Aquatic Center Staffing | | |
|--|-----------------|--------------|
| Lead Guards | \$15/hr | |
| Lifeguards | \$12/hr | |
| Concessions/Front Desk | \$10/hr | |
| WSI (Water Safety Instructors) | See note below | |
| Aquatics Coordinator | \$11,278/season | |
| <p>Note: Certified WSI (Water Safety Instructors) will receive \$1.00 per hour, on top of their hourly wages, during group swimming lessons</p> <p>Coordinator will receive additional hourly wages for group and private swimming lesson instruction. Lifeguarding shifts, both during open hours and lessons will be considered part of the stipend.</p> <p>All staff members will receive longevity incentive of an additional \$.25/hour for each year worked at City Aquatic Center</p> | | |
| Park Maintenance Staffing | | |
| Park Maintenance | \$15/hr | May - August |
| <p>Note: All staff members will receive longevity incentive of an additional \$.25/hour for each year worked at City Park Department</p> | | |

| Recreation Assistance Staffing | | |
|--|-------------------------|---|
| Concessions | \$10/hr | * Not to Exceed Soccer, Baseball, Softball, Flag Football |
| Tournament Concessions- Civic Group/Non Profit | 30% of sales NTE \$400* | |
| Rec Umpires | \$15 to \$30/game | |
| Program Leads | % of registrations | |
| Baseball/Softball Tournament Umpires | \$35 to \$80/game | |
| Baseball/Softball Tournament Site Rep | \$100-\$200/day | |
| Note: Aquatic employees who work recreation concession shifts will receive aquatic center hourly rate. (i.e returning staff may be at \$10.25 or \$10.50/hr) | | |

WHEREAS, The City Administrator and Park & Rec Director recommends the wages for the part-time seasonal staff, as noted above and

NOW, THEREFORE, The Council hereby approves the wages for the part-time seasonal staff, as noted above.

IN TESTIMONY WHEREOF, I have hereunto subscribed my name and caused the Great Seal of the City of Monticello, Iowa to be affixed hereto. Done this 6th day of April 2026.

Jake Ellwood, Mayor

Attest:

Sally Hinrichsen, City Clerk/Treasurer

City Council Meeting
Prep. Date: 04/01/2026
Preparer: Lori Lynch



Agenda Item: # 13
Agenda Date: 04/06/2026

Communication Page

Agenda Items Description: Changing Cora Wheeler from part time employee to Full time employee.

Type of Action Requested: Resolution

Attachments & Enclosures:

| |
|--|
| |
| |
| |

Fiscal Impact:

Budget Line Item:
Budget Summary:
Expenditure:
Revenue:

| |
|--|
| |
| |
| |
| |

Synopsis: Cora Wheeler is currently a part time AEMT. She would like to take the open full time position.

Background Information: When Sky Monty stepped down to part time an opening was left for a full time EMT/AEMT. Cora Wheeler is a student and had to wait until she got her class schedule, to make sure she could fulfill the position. She will be able to work the open position.

Staff Recommendation: Director Lynch recommends giving Wheeler the full time position.

City of Monticello, Iowa

RESOLUTION

Approving the hiring of a Monticello Ambulance
EMT/AEMT and setting wage

WHEREAS, a Monticello Full-Time Ambulance EMT/AEMT position has been open since EMT/AEMT Sky Monty stepped down to part-time, and,

WHEREAS, Ambulance Director Lori Lynch recommends promoting existing part-time EMT/AEMT Cora Wheeler to full-time EMT/AEMT and wish to offer her the position, and

WHEREAS, The City Council has set forth starting wages for AEMTs at \$24.79 per hour, and

WHEREAS, The City Administrator recommends promoting existing part-time EMT/AEMT Cora Wheeler to full-time EMT/AEMT and

WHEREAS, The Council finds it appropriate to follow the recommendation of the Ambulance Ambulance Director and the City Administrator, and further finds that the wages set by previous resolution are fair and reasonable and should, therefore, be approved.

NOW, THEREFORE, The Council hereby authorizes promoting existing part-time EMT/AEMT Cora Wheeler to full-time EMT/AEMT with a starting wage of \$24.79.

IN TESTIMONY WHEREOF, I have hereunto subscribed my name and caused the Great Seal of the City of Monticello, Iowa to be affixed hereto. Done this 6th day of April 2026.

Jake Ellwood, Mayor

Attest:

Sally Hinrichsen, City Clerk/Treasurer

CITY OF MONTICELLO, IOWA

RESOLUTION #2026-

Adopting Wage Chart for Full Time Hourly Employees for July 1, 2026 through June 30, 2029

WHEREAS, The City Council has determined adjustments to the wage scales are necessary for full time hourly staff, and

NOW THEREFORE BE IT RESOLVED that the City Council of Monticello, Iowa does hereby approve the amendment of the wages set forth in Exhibit A, attached hereto, all of said changes to take effect and be applicable to the first payroll issued during the month of July in the respective Fiscal Year. The City Council shall have the right to place new employees at a starting wage at any point in the wage scale, taking account the new employee's years of experience.

IN TESTIMONY WHEREOF, I have hereunto subscribed my name and caused the Great Seal for the City of Monticello, Iowa to be affixed. Done this 6th day of April, 2026.

Jake Ellwood, Mayor

Attest:

Sally Hinrichsen, City Clerk/Treasurer

| | FY26/27 (Starting July 1, 2026) | | | | | |
|----------------------------|---------------------------------|----------|----------|----------|----------|----------|
| | Years Completed with City* | | | | | |
| Position | Starting | Year 1 | Year 2 | Year 3 | Year 4 | Year 5 |
| Water/Wastewater | | | | | | |
| Licensed Operator | \$ 30.01 | \$ 30.61 | \$ 31.21 | \$ 31.81 | \$ 32.41 | \$ 33.01 |
| Operator ** | \$ 25.49 | \$ 26.52 | \$ 27.11 | \$ 27.71 | \$ 28.31 | \$ 28.91 |
| Public Works | | | | | | |
| Public Works Worker | \$ 25.14 | \$ 25.74 | \$ 26.34 | \$ 26.94 | \$ 27.54 | \$ 28.14 |
| Cemetery Sexton | \$ 25.14 | \$ 25.74 | \$ 26.34 | \$ 26.94 | \$ 27.54 | \$ 28.14 |
| City Clerk's Office | | | | | | |
| Payroll/Utility Billing | \$ 27.07 | \$ 27.67 | \$ 28.27 | \$ 28.87 | \$ 29.47 | \$ 30.07 |
| Account Clerk | \$ 25.83 | \$ 26.43 | \$ 27.03 | \$ 27.63 | \$ 28.23 | \$ 28.82 |
| Ambulance | | | | | | |
| Lead Paramedic | | | | | | \$ 33.14 |
| Paramedic | \$ 29.16 | \$ 29.68 | \$ 30.20 | \$ 30.77 | \$ 31.34 | \$ 31.91 |
| AEMT | \$ 25.72 | \$ 26.24 | \$ 26.76 | \$ 27.33 | \$ 27.90 | \$ 28.47 |
| EMT | \$ 22.30 | \$ 22.81 | \$ 23.33 | \$ 23.90 | \$ 24.47 | \$ 25.05 |
| Police Department | | | | | | |
| Non-Certified | \$ 29.43 | | | | | |
| Police Officer | \$ 33.98 | \$ 35.56 | \$ 37.14 | \$ 38.08 | \$ 39.66 | \$ 39.99 |
| School Resource Officer | | | | | | *** TBD |
| Sergeant | | | | | | \$ 42.58 |
| Admin Assistant | | | | | | \$ 25.01 |

*May be adjusted based upon experience

** \$1/hr increase for each grade license (in both water and wastewater, not just one)

*** SRO pay to be determined annually upon School and City funding agreement

^^^Certified Part-Time Officers shall be placed at starting step in the range

| | FY27/28 (Starting July 1, 2027) | | | | | |
|----------------------------|---------------------------------|----------|----------|----------|----------|----------|
| | Years Completed with City* | | | | | |
| Position | Starting | Year 1 | Year 2 | Year 3 | Year 4 | Year 5 |
| Water/Wastewater | | | | | | |
| Licensed Operator | \$ 31.14 | \$ 31.76 | \$ 32.38 | \$ 33.00 | \$ 33.62 | \$ 34.25 |
| Operator ** | \$ 26.45 | \$ 27.51 | \$ 28.13 | \$ 28.75 | \$ 29.37 | \$ 29.99 |
| Public Works | | | | | | |
| Public Works Worker | \$ 26.09 | \$ 26.71 | \$ 27.33 | \$ 27.95 | \$ 28.57 | \$ 29.19 |
| Cemetery Sexton | \$ 26.09 | \$ 26.71 | \$ 27.33 | \$ 27.95 | \$ 28.57 | \$ 29.19 |
| City Clerk's Office | | | | | | |
| Payroll/Utility Billing | \$ 28.09 | \$ 28.71 | \$ 29.33 | \$ 29.95 | \$ 30.57 | \$ 31.19 |
| Account Clerk | \$ 26.80 | \$ 27.42 | \$ 28.04 | \$ 28.66 | \$ 29.28 | \$ 29.91 |
| Ambulance | | | | | | |
| Lead Paramedic | | | | | | \$ 34.38 |
| Paramedic | \$ 30.26 | \$ 30.80 | \$ 31.33 | \$ 31.93 | \$ 32.52 | \$ 33.11 |
| AEMT | \$ 26.68 | \$ 27.22 | \$ 27.76 | \$ 28.35 | \$ 28.94 | \$ 29.54 |
| EMT | \$ 23.13 | \$ 23.67 | \$ 24.21 | \$ 24.80 | \$ 25.39 | \$ 25.98 |
| Police Department | | | | | | |
| Non-Certified | \$ 30.54 | | | | | |
| Police Officer | 35.25 | 36.90 | 38.54 | 39.51 | 41.15 | 41.48 |
| School Resource Officer | | | | | | *** TBD |
| Sergeant | | | | | | \$ 44.18 |
| Admin Assistant | | | | | | \$ 25.95 |

*May be adjusted based upon experience

** \$1/hr increase for each grade license (in both water and wastewater, not just one)

*** SRO pay to be determined annually upon School and City funding agreement

^^^Certified Part-Time Officers shall be placed at starting step in the range

| | FY28/29 (Starting July 1, 2028) | | | | | |
|----------------------------|---------------------------------|----------|----------|----------|----------|----------|
| | Years Completed with City* | | | | | |
| Position | Starting | Year 1 | Year 2 | Year 3 | Year 4 | Year 5 |
| Water/Wastewater | | | | | | |
| Licensed Operator | \$ 32.31 | \$ 32.95 | \$ 33.60 | \$ 34.24 | \$ 34.89 | \$ 35.53 |
| Operator ** | \$ 27.44 | \$ 28.54 | \$ 29.18 | \$ 29.83 | \$ 30.47 | \$ 31.12 |
| Public Works | | | | | | |
| Public Works Worker | \$ 27.06 | \$ 27.71 | \$ 28.35 | \$ 29.00 | \$ 29.64 | \$ 30.29 |
| Cemetery Sexton | \$ 27.06 | \$ 27.71 | \$ 28.35 | \$ 29.00 | \$ 29.64 | \$ 30.29 |
| City Clerk's Office | | | | | | |
| Payroll/Utility Billing | \$ 29.14 | \$ 29.78 | \$ 30.43 | \$ 31.07 | \$ 31.72 | \$ 32.36 |
| Account Clerk | \$ 27.80 | \$ 28.45 | \$ 29.09 | \$ 29.74 | \$ 30.38 | \$ 31.03 |
| Ambulance | | | | | | |
| Lead Paramedic | | | | | | \$ 35.67 |
| Paramedic | \$ 31.39 | \$ 31.95 | \$ 32.51 | \$ 33.12 | \$ 33.74 | \$ 34.35 |
| AEMT | \$ 27.68 | \$ 28.24 | \$ 28.80 | \$ 29.42 | \$ 30.03 | \$ 30.64 |
| EMT | \$ 24.00 | \$ 24.56 | \$ 25.12 | \$ 25.73 | \$ 26.34 | \$ 26.96 |
| Police Department | | | | | | |
| Non-Certified | \$ 31.68 | | | | | |
| Police Officer | \$ 36.58 | \$ 38.28 | \$ 39.98 | \$ 40.99 | \$ 42.69 | \$ 43.04 |
| School Resource Officer | | | | | | *** TBD |
| Sergeant | | | | | | \$ 45.83 |
| Admin Assistant | | | | | | \$ 26.92 |

*May be adjusted based upon experience

** \$1/hr increase for each grade license (in both water and wastewater, not just one) achieved after hire

*** SRO pay to be determined annually upon School and City funding agreement

^^^Certified Part-Time Officers shall be placed at starting step in the range

City of Monticello, Iowa

RESOLUTION #2026-

Adopting FY '27 Salaries and Wages for the Non-Hourly,
Library, Department Heads and Permanent Part-Time Staff

WHEREAS, most hourly permanent employees were granted 3 years of wage increases and other benefits by Resolution 2026-, and

WHEREAS, most part-time and seasonal employees were hired and granted wages by prior Resolutions of the Council, and

WHEREAS, Non-Hourly, Library, Department Heads and Permanent Part-Time Staff do not have negotiated employment agreements, and

WHEREAS, Other employees or positions still need salaries and/or wages set forth annually for a variety of reasons, and

WHEREAS, The City Council has historically approved wage or salary increases for those positions annually, and

WHEREAS, based upon the recommendation of the City Administrator the wages of On-Call Ambulance staff/volunteers shall be set as follows:

On-Call/Driver: \$8.00/Hour All employees regardless of Certification when **On-Call**
EMT: \$22.30/Hour **When On-A-Call/Treating or Transporting a Patient**
AEMT: \$25.72/Hour **When On-A-Call/Treating or Transporting a Patient**
Paramedic: \$29.16/Hour **When On-A-Call/Treating or Transporting a Patient**

WHEREAS, The Airport Manager is a “contract” position with the manager being paid an annual stipend by the City with the annual increase normally being based upon the recommendation of the Airport Commission, which recommended a stipend of \$34,650 for Fiscal Year 2027, and

WHEREAS, the Council finds that the following positions: Public Works Director, City Clerk, Park and Rec. Director, Park and Rec Superintendent, Water/Wastewater Superintendent, Ambulance Director, Police Chief and Library Director should receive a salary as stated below:

| | |
|--|-------------|
| Nick Kahler (Director of Public Works) | \$71,368.80 |
| Sally Hinrichsen (City Clerk) | \$87,567.15 |
| Jacob Oswald (Park and Rec Director) | \$71,251.06 |
| Milo Breitbach (Park and Rec Superintendent) | \$47,750.00 |
| Jim Tjaden (Water/Wastewater Superintendent) | \$80,610.71 |

| | |
|---------------------------------|-------------|
| Lori Lynch (Ambulance Director) | \$92,091.88 |
| Britt Smith (Police Chief) | \$99,097.99 |
| Faith Brehm (Library Director) | \$53,258.61 |

WHEREAS, Library Staff are granted annual wages with the advice and consent of the Library Board, which approved 7% wage increases as part of the FY '27 budget, therefore the wages shall be as follows:

| | |
|--|------------------|
| Molli Hunter (Technology and Adult Services) | \$19.21 per hour |
| Penny Schmit (Youth Services and Outreach) | \$22.80 per hour |

WHEREAS, the wage for the Adult Park and Recreation Part Time position shall be set as follows:

| | |
|-----------------------------------|------------------|
| Kara Burrack (Adult Programs P/T) | \$22.95 per hour |
|-----------------------------------|------------------|

WHEREAS, the wage for the Police Department School Resource Officer (SRO) shall be set as follows:

| | |
|--------------------------------------|------------------|
| Erik Honda (School Resource Officer) | \$37.78 per hour |
|--------------------------------------|------------------|

WHEREAS, the wages and salaries outlined above shall take effect with the 1st pay period including July 1, 2026

NOW THEREFORE BE IT RESOLVED that the City Council of Monticello, Iowa does hereby approve of the wages and salary increases as set out above, all of said wages and salaries shall be retroactive, if necessary, in order to take effect and be applicable to the first payroll issued during the month of July, 2026.

IN TESTIMONY WHEREOF, I have hereunto subscribed my name and caused the Great Seal for the City of Monticello, Iowa to be affixed. Done this 6th day of April, 2026.

Jake Ellwood, Mayor

Attest:

Sally Hinrichsen, City Clerk/Treasurer

City of Monticello, Iowa

RESOLUTION #2026-

Updating the salary and residency requirements, and otherwise affirm the Employment Agreement of Russell Farnum as City Administrator

WHEREAS, Russell Farnum has served as the City Administrator since March 1, 2021, and

WHEREAS, the City Council is overall pleased with his performance, and

WHEREAS, the City Council has agreed to amend the salary for this position to \$97,700.00, with no other changes to the other benefits set forth in the Employment Agreement for this position, and the Council finds the proposed salary and benefits to be appropriate, and

WHEREAS, the City Council has agreed to extend the residency requirement for one year in accordance with the Employment Agreement.

NOW, THEREFORE, The Council hereby affirms the continuance of the Employment Agreement with Russell Farnum, as the City Administrator, with the changes specifically outlined herein, and the amended salary shall take effect with the 1st pay period including July 1, 2026.

IN TESTIMONY WHEREOF, I have hereunto subscribed my name and caused the Great Seal of the City of Monticello, Iowa to be affixed hereto. Done this 6th day of April, 2026.

Jake Ellwood, Mayor

Attest:

Sally Hinrichsen, City Clerk/Treasurer

City Council Meeting
Prep. Date: 04/01/2026
Preparer: Russell Farnum



Agenda Item: #17
Agenda Date: 04/06/2026

Communication Page

Agenda Items Description: Parcel 2026-24 (Struve)

Type of Action Requested: Resolution

Attachments & Enclosures:

| |
|------------|
| Resolution |
| Plat |
| |

Fiscal Impact:

| | |
|-------------------|--|
| Budget Line Item: | |
| Budget Summary: | |
| Expenditure: | |
| Revenue: | |

Synopsis: Sara Struve owns two parcels of land northwest of town on Hardscrabble Road. The property is unincorporated, but still within the City’s extraterritorial jurisdiction for reviewing subdivisions.

One parcel of the property is about thirty three and a half acres, and includes the homestead area on the south side of Hardscrabble Road, and some woods, creek and pasture land on the north side of the road. The second parcel is a triangle of land about two and a half acres in size, and is located south of the homestead portion of the property. These are shown on the locator map.

This proposed plat would split the property along the roadway, and combine the homestead parcel with the adjacent vacant property to the south. The parcel north of Hardscrabble would become its own lot.

The property consists of two parcels now, and this plat essentially moves the lot line to follow the roadway. This proposal will not create any new lots, nor will it impact the future growth or development of the City.

Recommendation:

Planning and Zoning reviewed this parcel at their regular meeting of March 24, and unanimously recommended approval.

City of Monticello, Iowa

RESOLUTION #2026-

Approving Plat of Survey to Parcel 2026-24 located at 17213 Hardscrabble Road

WHEREAS, The Plat of Survey to Parcel 2026-24 for property located at 17213 Hardscrabble Road has been presented to the City Council for approval, same being located within the extraterritorial plat review jurisdiction of the City of Monticello, and

WHEREAS, the Plat was created to subdivide the portion of the parcel from the south side of Hardscrabble Road from the portion of the parcel on the north side of the road, and combines the south portion with an adjacent parcel, and

WHEREAS, The City Planning and Zoning Board has reviewed the Plat of Survey and recommends that it be approved, and

WHEREAS, The City Council finds that the Plat of Survey for Parcel 2026-24, for property located at 17213 Hardscrabble Road should be approved.

NOW, THEREFORE, BE IT RESOLVED that the City Council of Monticello, Iowa does hereby approve the Plat of Survey for Parcel 2026-24.

IN TESTIMONY WHEREOF, I have hereunto subscribed my name and caused the Great Seal of the City of Monticello, Iowa to be affixed hereto.
Done this 6th day of April, 2026.

Jake Ellwood, Mayor

Attest:

Sally Hinrichsen, City Clerk/Treasurer



Jones County, IA

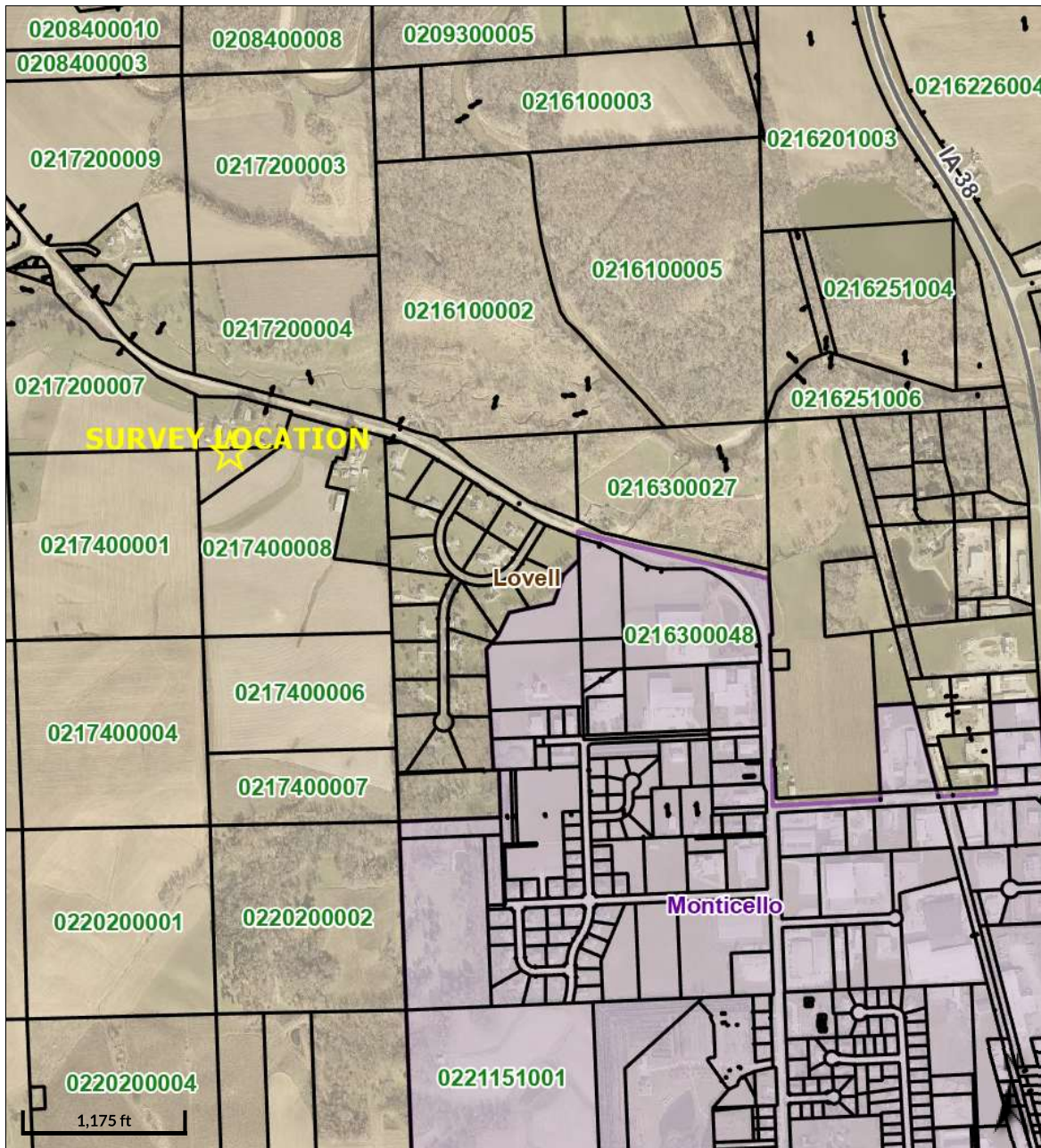

Overview

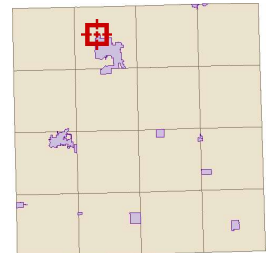

Legend

- Corporate Limits
- Political Townships
- Parcels
- Cartography
- Major Roads

THIS MAP DOES NOT REPRESENT A SURVEY. NO LIABILITY IS ASSUMED FOR THE ACCURACY OF THE DATA DELINEATED HEREIN, EITHER EXPRESSED OR IMPLIED BY JONES COUNTY OR ITS EMPLOYEES. THIS MAP IS COMPILED FROM OFFICIAL RECORDS, INCLUDING PLATS, SURVEYS, RECORDED DEEDS, AND CONTRACTS, AND ONLY CONTAINS INFORMATION REQUIRED FOR LOCAL GOVERNMENT PURPOSES. SEE THE RECORDED DOCUMENTS FOR MORE DETAILED LEGAL INFORMATION.

Date created: 3/13/2026

Last Data Uploaded: 3/12/2026 5:38:32 PM

Developed by SCHNEIDER
GEOSPATIAL

INDEX LEGEND

LOCATION: SE1/4, NE1/4 AND NE1/4, SE1/4 SECTION 17, T86N, R3W

PROPRIETORS: SARA L. STRUVE REVOCABLE TRUST - SARA L. STRUVE TRUSTEE

REQUESTOR: MIKE MCDONOUGH

SURVEYOR: BILL BURGER

SURVEYOR COMPANY: WM. BURGER LANDSURVEYOR

RETURN TO: BILL BURGER, 510 3RD STREET WEST COURT, WORTHINGTON, IA 52078 (563) 855-2028

PREPARED BY BILL BURGER 510 3RD STREET WEST COURT, WORTHINGTON, IOWA 52078 (563) 855 2028

PLAT OF SURVEY

PARCEL 2026-24 PART OF THE SOUTHEAST QUARTER (SE1/4) OF THE NORTHEAST QUARTER (NE1/4) AND PART OF NORTHEAST QUARTER (NE1/4) OF THE SOUTHEAST QUARTER (SE1/4) ALL IN SECTION SEVENTEEN (17), TOWNSHIP EIGHTY-SIX NORTH (T86N) RANGE THREE WEST (R3W) OF THE FIFTH PRINCIPAL MERIDIAN, JONES COUNTY, IOWA

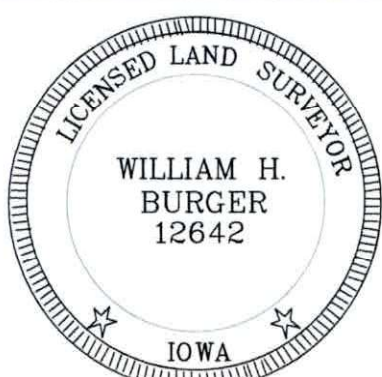
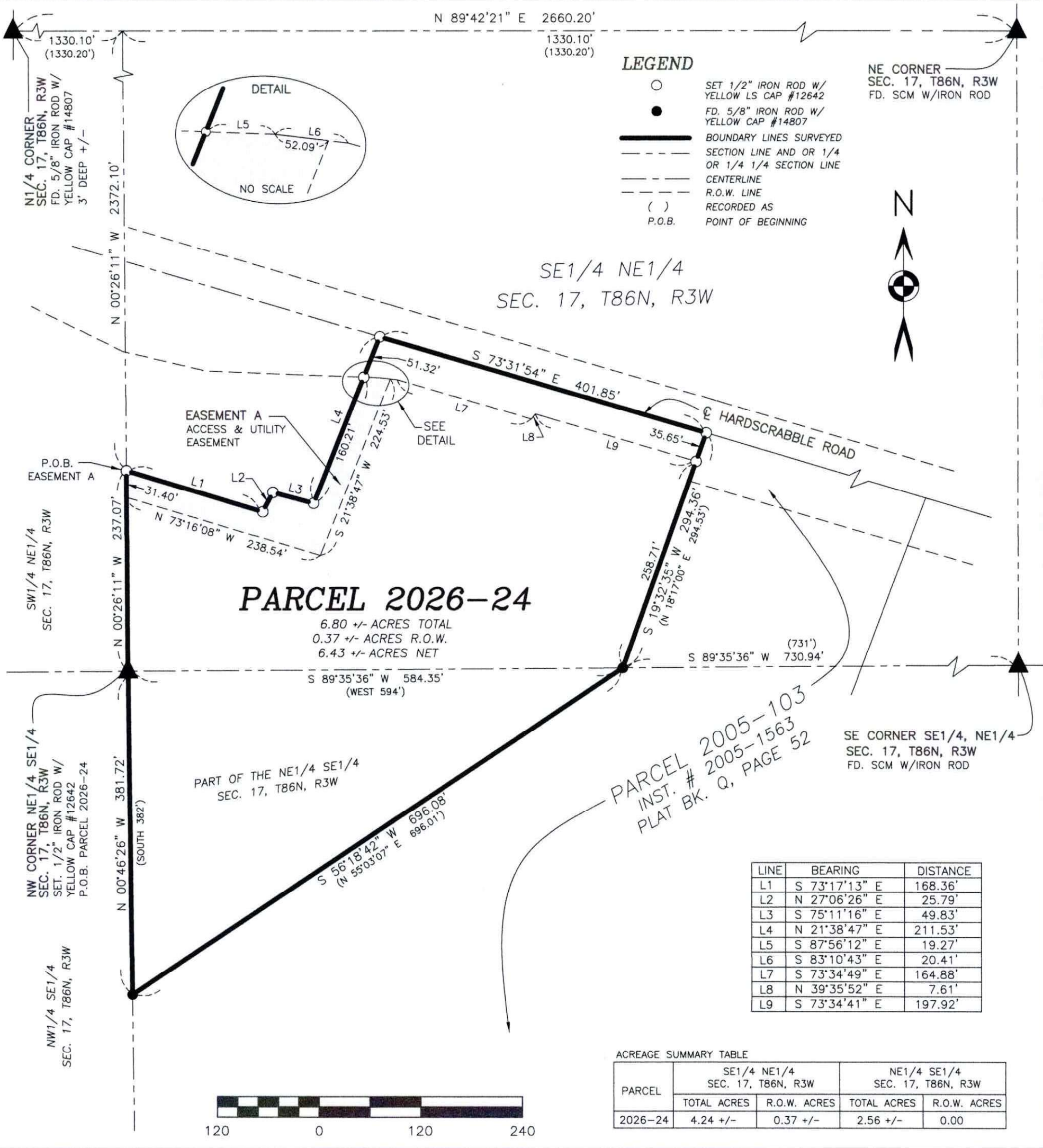

DATE OF SURVEY: 3/4/2026 SCALE: 1" = 120' SHEET 1 OF 3

PROPRIETORS: SEE INDEX LEGEND

I HEREBY CERTIFY THAT THIS LANDSURVEYING DOCUMENT WAS PREPARED AND RELATED SURVEY WORK WAS PERFORMED BY ME OR UNDER MY DIRECT PERSONAL SUPERVISION AND THAT I AM A DULY LICENSED LAND SURVEYOR UNDER THE LAWS OF THE STATE OF IOWA. MY LICENSE RENEWAL DATE IS DECEMBER 31, 2026

Wm. Burger
LandSurveyor
510 3rd Street West Court
Worthington, Iowa 52078

WILLIAM H. BURGER #12642 DATE 3/13/26

City Council Meeting
Prep. Date: 04/01/2026
Preparer: Russell Farnum



Agenda Item: # 18 - 20
Agenda Date: 04/06/2026

Communication Page

Agenda Items Description: Parcel 2026-25, 2026-26, Site Plan (Hinz-Tri County Propane)

Type of Action Requested: Resolutions (3)

Attachments & Enclosures:

| |
|-------------------|
| Resolutions (3) |
| Plats (2) |
| Amended Site Plan |

Fiscal Impact:

| | |
|-------------------|--|
| Budget Line Item: | |
| Budget Summary: | |
| Expenditure: | |
| Revenue: | |

Synopsis: Robert and Janice Hinz own Tri-County Propane, and recently built their truck garage on Lot 1 of Brad Stephen’s Fourth Addition at 1503 South Main Street. They are now proposing to purchase some additional land to the north to make truck access easier for their property, and propose construction of their office building.

Plats

The proposed plat of Parcel 2026-25 subdivides a 20 foot strip from the Stephen property to the north, and Parcel 2026-26 combines that strip with the Hinz property.

Revised Site Plan

When this project was approved, the new truck access was not anticipated as part of the site plan. In addition, the office building was going to be constructed closer to the Main street frontage and south a bit more, and now Hinz’s would like to move the building north to line up with the truck building. These changes are outlined on the attached drawing.

Background

The property is annexed and zoned M-1 Light Industrial, and the revised site plan meets all setbacks and other requirements of that district. The buildings will be connected to City sewer and water now that the utilities are available (the property is already annexed).

The proposed office building will be 26 feet by 44 feet, and will match the truck garage, with gray siding and charcoal-colored stone wainscoting, pillars, and corner treatments. A covered entrance will face the parking on the south side of the building, and windows will be on the three visible sides of the

building. Drawings of the proposed building are attached, as is the site plan showing the changes from the original approval.

The required landscaping has already been completed with a number of trees planted along the front and south sides of the lot.

Recommendation:

Planning and Zoning reviewed the plats and site plan at their regular meeting of March 24, and unanimously recommended approval.

City of Monticello, Iowa

RESOLUTION #2026-

Approving Plat of Survey to Parcel 2026-25 located Just North of 1503 S Main Street

WHEREAS, The Plat of Survey to Parcel 2026-25 for property located just north of 1503 S. Main Street has been presented to the City Council for approval, same being located within Corporate Limits of the City of Monticello, and

WHEREAS, the Plat was created to subdivide the portion of the parcel from the south end of the Stephen Property, intended to expand the lot just south of the Parcel by an additional 20 feet, and

WHEREAS, The City Planning and Zoning Board has reviewed the Plat of Survey and recommends that it be approved, and

WHEREAS, The City Council finds that the Plat of Survey for Parcel 2026-25, for property located just north of 1503 S. Main Street should be approved.

NOW, THEREFORE, BE IT RESOLVED that the City Council of Monticello, Iowa does hereby approve the Plat of Survey for Parcel 2026-25.

IN TESTIMONY WHEREOF, I have hereunto subscribed my name and caused the Great Seal of the City of Monticello, Iowa to be affixed hereto.
Done this 6th day of April, 2026.

Jake Ellwood, Mayor

Attest:

Sally Hinrichsen, City Clerk/Treasurer

| | |
|--|---|
| LOCATION: A PORTION OF THE SOUTHWEST QUARTER OF THE NORTHWEST QUARTER OF SECTION 34, TOWNSHIP 86 NORTH, RANGE 3 WEST, OF THE FIFTH PRINCIPAL MERIDIAN, JONES COUNTY IOWA | REQUESTED BY: ROGER W STEPHEN, 1011 S MAIN ST MONTICELLO, IOWA 52310 |
| LAND SURVEYOR: RICHARD R. NOWOTNY P.L.S MMS CONSULTANTS INC. 1917 SOUTH GILBERT STREET IOWA CITY, IOWA, 52240 PHONE: 319-351-8282 | PROPRIETOR OR OWNER: ROGER W STEPHEN, 1011 S MAIN ST MONTICELLO, IOWA 52310 |
| DATE OF SURVEY: 06-11-2023 | |

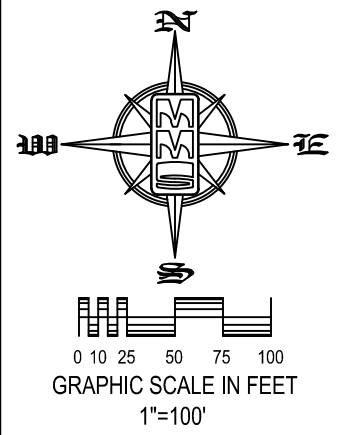

FOR COUNTY RECORDER'S USE

PLAT OF SURVEY PARCEL 2026-25 MONTICELLO, JONES COUNTY, IOWA

| LEGEND AND NOTES | |
|------------------|--|
| | - CONGRESSIONAL CORNER, FOUND |
| | - PROPERTY CORNER(S), FOUND (as noted) |
| | - PROPERTY CORNERS SET (5/8" Iron Pin w/ yellow, plastic LS Cap embossed with "MMS") |
| | - CUT "X" |
| | - PROPERTY &/or BOUNDARY LINES |
| | - CONGRESSIONAL SECTION LINES |
| | - RIGHT-OF-WAY LINES |
| | - CENTER LINES |
| | - LOT LINES, INTERNAL |
| | - LOT LINES, PLATTED OR BY DEED |
| | - EASEMENT LINES, WIDTH & PURPOSE NOTED |
| | - EXISTING EASEMENT LINES, PURPOSE NOTED |
| | - RECORDED DIMENSIONS |
| | - MEASURED DIMENSIONS |
| | - CURVE SEGMENT NUMBER |
| (R) | - RECORDED DIMENSIONS |
| (M) | - MEASURED DIMENSIONS |
| C22-1 | - CURVE SEGMENT NUMBER |

UNLESS NOTED OTHERWISE, ALL DIMENSIONS ARE IN FEET AND HUNDREDTHS

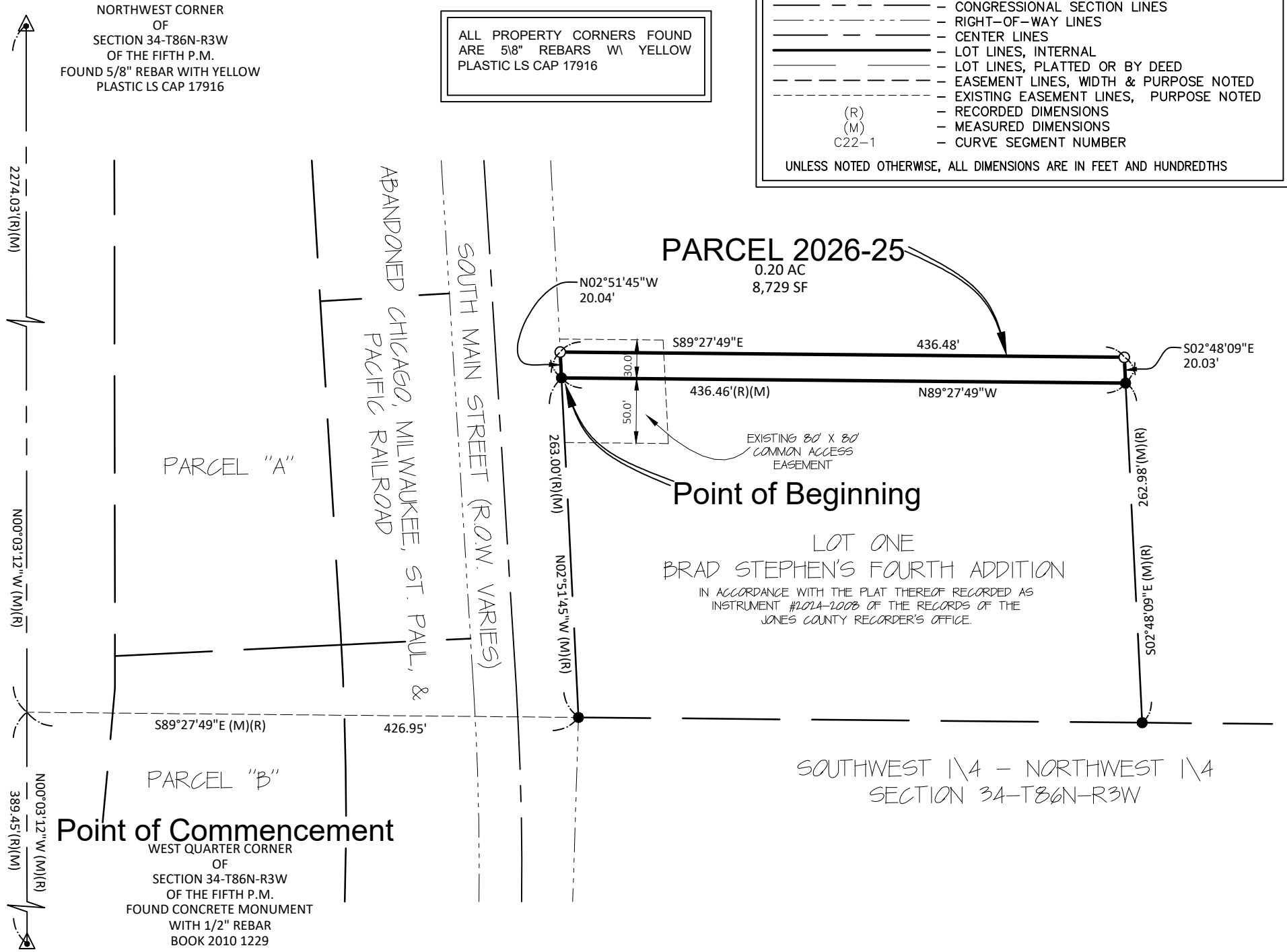

DESCRIPTION - PARCEL 2026-25

Commencing at the West Quarter Corner of Section 34, Township 86 North, Range 3 West, of the Fifth Principal Meridian, Monticello, Jones County, Iowa; Thence N00°03'12"W, along the West Line of the Northwest Quarter of said Section 34, a distance of 389.45 feet; Thence S89°27'49"E, 426.95 feet, to a Point on the Easterly Right-of-Way Line of South Main Street (US Business 151), and the Southwest Corner of Brad Stephen's Fourth Addition, in accordance with the Plat thereof Recorded as Instrument #2024-2008 of the Records of the Jones County Recorder's Office; Thence N02°51'45"W, along said Easterly Right-of-Way Line, and the Westerly Line of said Brad Stephen's Fourth Addition, 263.00 feet, to the Northwest Corner of said Brad Stephen's Fourth Addition, and the POINT OF BEGINNING; Thence continuing N02°51'45"W, along said Easterly Right-of-Way Line, 20.04 feet; Thence S89°27'49"E, along a Line parallel with and 20.00 feet normally distant Northerly from the North Line of said Brad Stephen's Fourth Addition, 436.48 feet, to its intersection with the Northerly Projection of the East Line of said Brad's Stephen's Fourth Addition; Thence S02°48'09"E, along said Northerly Projection, 20.03 feet, to the Northeast Corner of said Brad Stephens Fourth Addition; Thence N89°27'49"W, along the North Line of said Brad Stephen's Fourth Addition, 436.46 feet, to the POINT OF BEGINNING. Said Parcel 2026-25 contains 8,729 square feet, and is subject to easements and restrictions of record.

SEAL

I hereby certify that this land surveying document was prepared and the related survey work was performed by me or under my direct personal supervision and that I am a duly licensed Professional Land Surveyor under the laws of the State of Iowa.

_____, 20____

RICHARD R. NOWOTNY
P.L.S. Iowa Lic. No. 17916

My license renewal date is December 31, 20____.

Pages or sheets covered by this seal: _____

**MONTICELLO
JONES COUNTY
IOWA**

MMS CONSULTANTS, INC.

Date: 03-12-2026

Designed by: RRN
Field Book No.: 1328, 1390

Drawn by: RLW
Scale: 1" = 100'

Checked by: RRN
Sheet No.: 1

Project No.: IC 7502-006
of: 1

PLAT OF SURVEY

PARCEL 2026-25

Date: 03-12-2026
Revision: PER RRN REVIEW - RLW

www.mmsconsultants.net

1917 S. GILBERT ST.
IOWA CITY, IOWA 52240
(319) 351-8282

CIVIL ENGINEERS
LAND PLANNERS
LAND SURVEYORS
LANDSCAPE ARCHITECTS
ENVIRONMENTAL SPECIALISTS

City of Monticello, Iowa

RESOLUTION #2026-

Approving Plat of Survey to Parcel 2026-26 located at 1503 South Main Street

WHEREAS, The Plat of Survey to Parcel 2026-26 for property located at 1503 S Main Street has been presented to the City Council for approval, same being located within the Corporate Limits of the City of Monticello, and

WHEREAS, the Plat was created to combine Parcel 2026-25 with the adjacent parcel, being Lot 1 of Brad Stephen 4th Addition, and

WHEREAS, The City Planning and Zoning Board has reviewed the Plat of Survey and recommends that it be approved, and

WHEREAS, The City Council finds that the Plat of Survey for Parcel 2026-26, for property located at 1503 S Main Street should be approved.

NOW, THEREFORE, BE IT RESOLVED that the City Council of Monticello, Iowa does hereby approve the Plat of Survey for Parcel 2026-26.

IN TESTIMONY WHEREOF, I have hereunto subscribed my name and caused the Great Seal of the City of Monticello, Iowa to be affixed hereto.
Done this 6th day of April, 2026.

Jake Ellwood, Mayor

Attest:

Sally Hinrichsen, City Clerk/Treasurer

| | |
|--|---|
| LOCATION: A PORTION OF THE SOUTHWEST QUARTER OF THE NORTHWEST QUARTER OF SECTION 34, TOWNSHIP 86 NORTH, RANGE 3 WEST, OF THE FIFTH PRINCIPAL MERIDIAN, JONES COUNTY IOWA | REQUESTED BY: ROGER W STEPHEN, 1011 S MAIN ST MONTICELLO, IOWA 52310 |
| LAND SURVEYOR: RICHARD R. NOWOTNY P.L.S MMS CONSULTANTS INC. 1917 SOUTH GILBERT STREET IOWA CITY, IOWA, 52240 PHONE: 319-351-8282 | PROPRIETOR OR OWNER: ROGER W STEPHEN, 1011 S MAIN ST MONTICELLO, IOWA 52310 |
| DATE OF SURVEY: 06-11-2023 | |

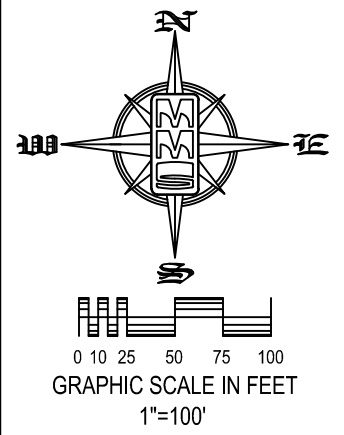

FOR COUNTY RECORDER'S USE

PLAT OF SURVEY PARCEL 2026-26

LOT 1 OF BRAD STEPHENS' FOURTH ADDITION AND PARCEL 2026-25
MONTICELLO, JONES COUNTY, IOWA

NORTHWEST CORNER OF SECTION 34-T86N-R3W OF THE FIFTH P.M. FOUND 5/8" REBAR WITH YELLOW PLASTIC LS CAP 17916

ALL PROPERTY CORNERS FOUND ARE 5/8" REBARS W/ YELLOW PLASTIC LS CAP 17916

LEGEND AND NOTES

- ▲ - CONGRESSIONAL CORNER, FOUND
- - PROPERTY CORNER(S), FOUND (as noted)
- - PROPERTY CORNERS SET (5/8" Iron Pin w/ yellow, plastic LS Cap embossed with "MMS")
- ⊗ - CUT "X"
- — — — — - PROPERTY &/or BOUNDARY LINES
- — — — — - CONGRESSIONAL SECTION LINES
- - - - - - RIGHT-OF-WAY LINES
- — — — — - CENTER LINES
- — — — — - LOT LINES, INTERNAL
- — — — — - LOT LINES, PLATTED OR BY DEED
- - - - - - EASEMENT LINES, WIDTH & PURPOSE NOTED
- - - - - - EXISTING EASEMENT LINES, PURPOSE NOTED
- (R) - RECORDED DIMENSIONS
- (M) - MEASURED DIMENSIONS
- C22-1 - CURVE SEGMENT NUMBER

UNLESS NOTED OTHERWISE, ALL DIMENSIONS ARE IN FEET AND HUNDREDTHS

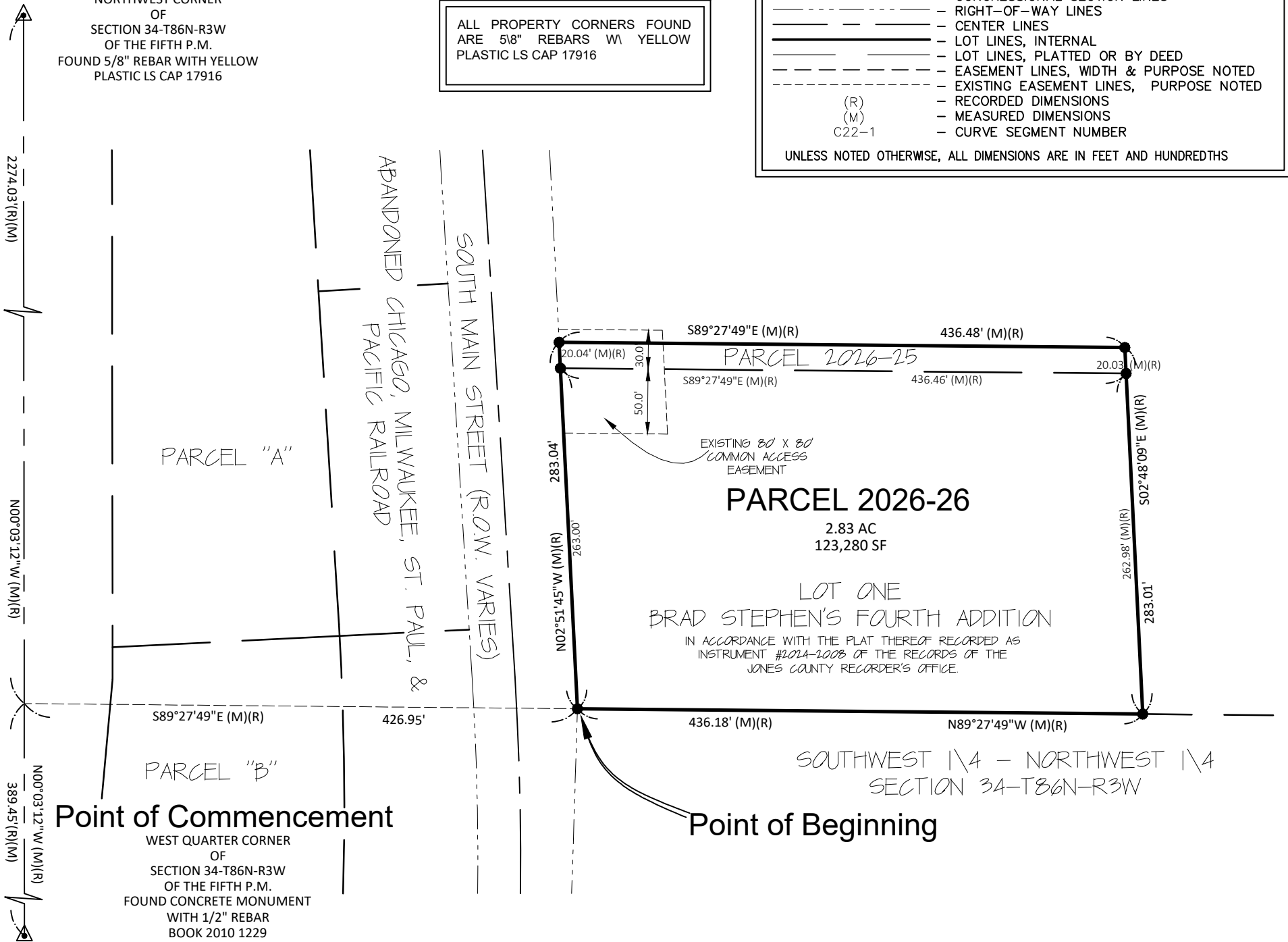

DESCRIPTION - PARCEL 2026-26

Commencing at the West Quarter Corner of Section 34, Township 86 North, Range 3 West, of the Fifth Principal Meridian, Monticello, Jones County, Iowa; Thence N00°03'12"W, along the West Line of the Northwest Quarter of said Section 34, a distance of 389.45 feet; Thence S89°27'49"E, 426.95 feet, to a Point on the Easterly Right-of-Way Line of South Main Street (US Business 151), the Southwest Corner of Brad Stephen's Fourth Addition, in accordance with the Plat thereof Recorded as Instrument #2024-2008 of the Records of the Jones County Recorder's Office, and the POINT OF BEGINNING; Thence N02°51'45"W, along said Easterly Right-of-Way Line, the Westerly Line of said Brad Stephen's Fourth Addition, and the West Line of Parcel 25, in accordance with the Recorded Plat thereof, 283.04 feet, to the Northwest Corner of said Parcel 25; Thence S89°27'49"E, along the North Line of said Parcel 25, a distance of 436.48 feet; Thence S02°48'09"E, along the East Line of Parcel 25, and the East Line of Brad Stephen's Fourth Addition, 283.01 feet, to the Southeast Corner of said Brad Stephens Fourth Addition; Thence N89°27'49"W, along the South Line of said Brad Stephen's Fourth Addition, 436.18 feet, to the POINT OF BEGINNING. Said Parcel 2026-26 contains 2.83 Acres, and is subject to easements and restrictions of record.

SEAL

I hereby certify that this land surveying document was prepared and the related survey work was performed by me or under my direct personal supervision and that I am a duly licensed Professional Land Surveyor under the laws of the State of Iowa.

_____ 20__

RICHARD R. NOWOTNY
P.L.S. Iowa Lic. No. 17916

My license renewal date is December 31, 20__.

Pages or sheets covered by this seal:

| | | | | | | | | | | | | | | |
|--|------------------------|---|------------------------------|--|---|--------------------------------------|--------------------------------------|--|-----------------------------------|--------------------------------------|-------------------------------------|----------------------------------|--|----------------------------------|
| <p>DATE</p> <p>03-12-2026 per rrr review -rlw</p> | <p>REVISION</p> | <p>PROJECT</p> <p>PARCEL 2026-26</p> | <p>PLAT OF SURVEY</p> | <p>CLIENT</p> <p>MONTICELLO JONES COUNTY IOWA</p> | <p>CONSULTANT</p> <p>MMS CONSULTANTS, INC.</p> | <p>DATE</p> <p>03-12-2026</p> | <p>DESIGNED BY</p> <p>RRN</p> | <p>FIELD BOOK NO.</p> <p>1328, 1390</p> | <p>DRAWN BY</p> <p>RLW</p> | <p>SCALE</p> <p>1" = 100'</p> | <p>CHECKED BY</p> <p>RRN</p> | <p>SHEET NO.</p> <p>1</p> | <p>PROJECT NO.</p> <p>IC 7502-006</p> | <p>SHEET NO.</p> <p>1</p> |
|--|------------------------|---|------------------------------|--|---|--------------------------------------|--------------------------------------|--|-----------------------------------|--------------------------------------|-------------------------------------|----------------------------------|--|----------------------------------|

WWW.MMSCONSULTANTS.NET

1917 S. GILBERT ST.
IOWA CITY, IOWA 52240
(319) 351-8282

CIVIL ENGINEERS
LAND PLANNERS
LAND SURVEYORS
LANDSCAPE ARCHITECTS
ENVIRONMENTAL SPECIALISTS

The City of Monticello, Iowa

RESOLUTION #2026-

Approving Amended Tri-County Propane Site Plan (Hinz)

WHEREAS, Robert and Jan Hinz have presented the Tri County Propane Site Plan for review and consideration on property known as Lot 1 of Brad Stephen's 4th Addition, which was approved on the 7th day of July, 2025, by Resolution 2025-91, and

WHEREAS, The proposed Site Plan calls for a truck storage building, bulk tanks for liquid propane, and a future office building, and

WHEREAS, Robert and Jan Hinz are now ready to construct the office building and have presented an amended Tri County Propane Site Plan for review and consideration, and

WHEREAS, The amended Site Plan has been reviewed by the City staff and the Planning and Zoning Board, and

WHEREAS, The Planning & Zoning Board unanimously recommended the approval of the site plan.

NOW, THEREFORE, BE IT RESOLVED that the City Council of Monticello, Iowa does hereby approve the amended Tri-County Propane Site Plan.

IN TESTIMONY WHEREOF, I have hereunto subscribed my name and caused the Great Seal of the City of Monticello, Iowa to be affixed hereto.
Done this 6th day of April, 2026.

Jake Ellwood, Mayor

Attest:

Sally Hinrichsen, City Clerk/Treasurer



CIVIL ENGINEERS
 LAND PLANNERS
 LAND SURVEYORS
 LANDSCAPE ARCHITECTS
 ENVIRONMENTAL SPECIALISTS

1917 S. GILBERT ST.
 IOWA CITY, IOWA 52240
 (319) 351-8282
 www.mmsconsultants.net

| Date | Revision |
|------|----------|
| | |

**SWPPP
 LOT 1**

BRAD STEPHEN'S
 FOURTH ADDITION
 MONTICELLO
 JONES COUNTY
 IOWA

MMS CONSULTANTS, INC.
 Date: 01/15/2025
 Designed by: RLA
 Drawn by: RLW/LRS
 Checked by: RLA
 Project No.: 12110-001
 of: 1



EROSION CONTROL LEGEND—ALL MEASURES SHALL MEET SUDAS SPECIFICATIONS

| | | | |
|--|---|--|--------------------------------------|
| | SILT FENCE / FILTER SOCK | | FILTER SOCK BEHIND CURB AT CURB RAMP |
| | TEMPORARY ROCK CONSTRUCTION ENTRANCE/EXIT | | GRADING/CONSTRUCTION UNITS |
| | TEMPORARY PARKING AND STORAGE | | RIP RAP OUTLET PROTECTION |
| | CONCRETE TRUCK/EQUIPMENT WASHOUT | | TEMPORARY SOIL STOCKPILE AREA |
| | PORTABLE RESTROOM | | PROPERTY &/OR BOUNDARY LINES |
| | DOCUMENT LOCATION (PERMITS, SWPPP, FORMS, ETC.) | | EXISTING RIGHT-OF-WAY LINES |
| | DIRECTION OF OVERLAND FLOW | | EXISTING CENTER LINES |
| | FILTER SOCK INLET PROTECTION | | |

THE ABOVE LISTED ITEMS ARE SHOWN IN THEIR RECOMMENDED LOCATIONS. IF A CONTROL MEASURE IS ADDED OR MOVED TO A LOCATION OTHER THAN THAT SHOWN, THE SWPPP MUST BE REVISED TO REFLECT THE CHANGES. THE SWPPP MUST BE REVISED TO REFLECT THE CHANGES. OTHER MEASURES SHOULD BE USED IF A NEW MEASURE ABOVE IS IMPLEMENTED ON SITE. ADDITIONAL PRECAUTIONS FOR EROSION PREVENTION AND SEDIMENT CONTROL CAN BE FOUND IN APPENDIX D OF THE SWPPP.

NOTES:
 *THESE DRAWINGS WERE PREPARED IN ACCORDANCE WITH PROVIDED BUILDING PLANS AND APPROVED AT THE DIRECTIVE OF THE APPLICANT. IT IS THE RESPONSIBILITY OF THE GENERAL CONTRACTOR TO VERIFY ALL APPROVED PERMIT CONDITIONS AND CONDITIONS ARE NOT RESPONSIBLE FOR ANY INCONSISTENCIES IN WHAT HAS BEEN PROVIDED AND REPRESENTED ON THESE DRAWINGS WITHOUT OUR EXPRESSED KNOWLEDGE AND APPROVAL. ALL CONSTRUCTION SHALL COMPLY WITH ALL APPLICABLE STATE AND/OR LOCAL CODES.

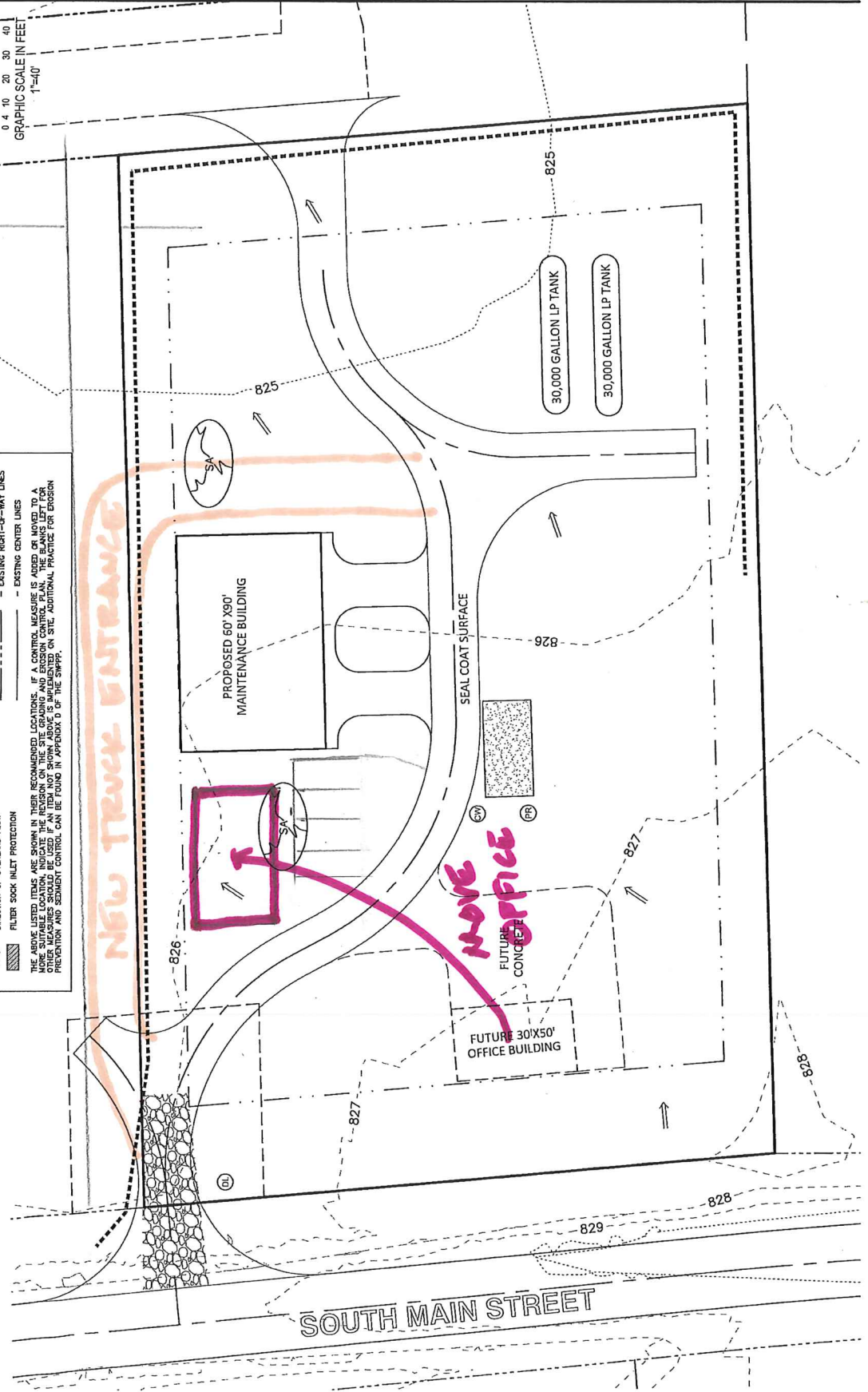

Tri County Propane

FACING SOUTH

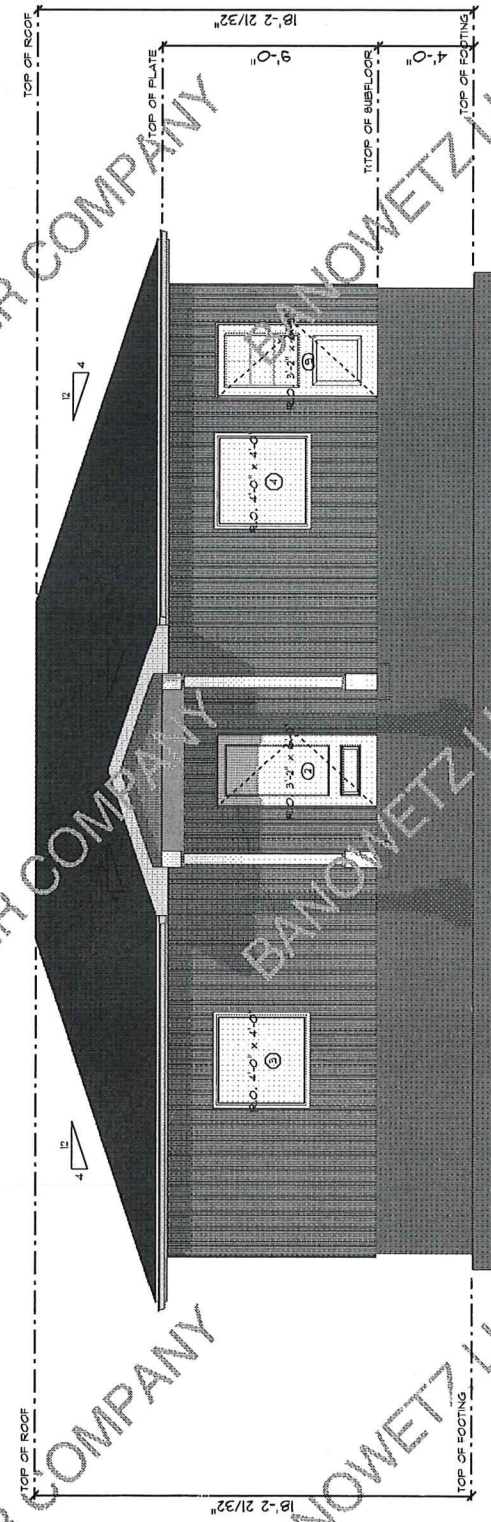

BANOWETZ LUMBER COMPANY



front north

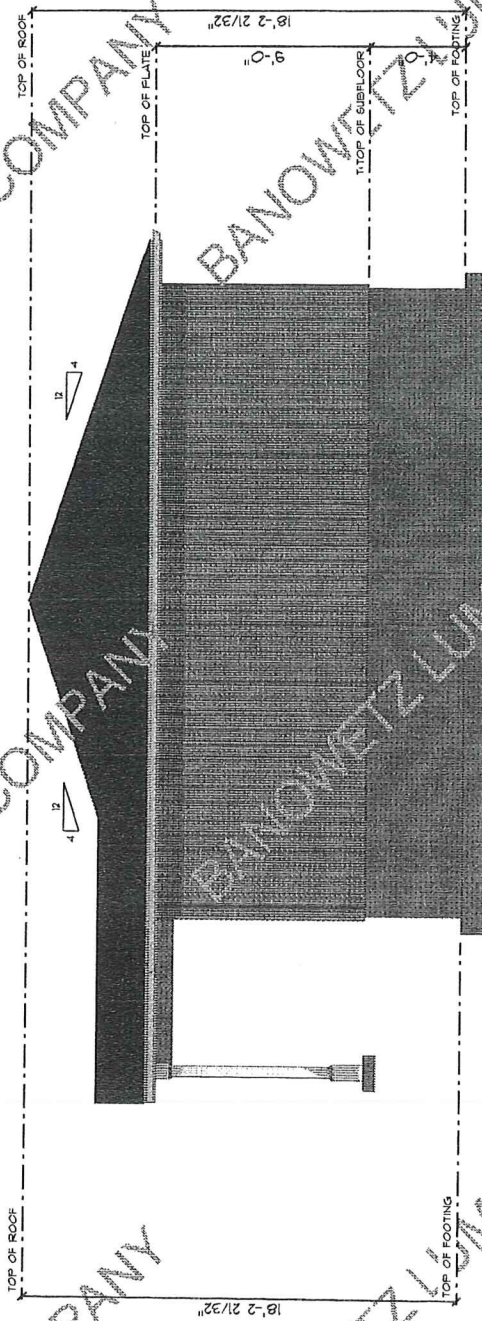

Facilitate Between Builders

BANOWETZ LUMBER COMPANY

City Council Meeting
Prep. Date: 04/01/2026
Preparer: Russell Farnum



Agenda Item: # 21
Agenda Date: 04/06/2026

Communication Page

Agenda Items Description: Parcel 2026-27 (Bowers)

Type of Action Requested: Resolution

| <u>Attachments & Enclosures:</u> |
|---|
| Resolution |
| |
| |

| <u>Fiscal Impact:</u> | |
|------------------------------|--|
| Budget Line Item: | |
| Budget Summary: | |
| Expenditure: | |
| Revenue: | |

Synopsis: James Bowers owns two adjacent lots on Varvel Street, between Sycamore and Maple Streets. One parcel (205 E Varvel) includes his home, detached garage and shed, and the second adjacent parcel (207 E Varvel) is vacant except for a driveway and a garage foundation.

Bowers would like to build an accessory structure on the vacant parcel, but the City ordinance does not allow an accessory structure alone on its own lot. Therefore, Bowers needs to combine the lots into one parcel.

This plat correctly accomplishes that purpose and would have no impact upon the character or development of the surrounding neighborhood.

Recommendation:

Planning and Zoning reviewed this parcel at their regular meeting of March 24, and unanimously recommended approval.

City of Monticello, Iowa

RESOLUTION #2026-

Approving Plat of Survey to Parcel 2026-27 located at 205 East Varvel Street

WHEREAS, The Plat of Survey to Parcel 2026-27 for property located at 205 E Varvel Street has been presented to the City Council for approval, same being located within the Corporate Limits of the City of Monticello, and

WHEREAS, the Plat was created to combine two adjacent properties into one parcel, and

WHEREAS, The City Planning and Zoning Board has reviewed the Plat of Survey and recommends that it be approved, and

WHEREAS, The City Council finds that the Plat of Survey for Parcel 2026-27, for property located at 205 E Varvel Street should be approved.

NOW, THEREFORE, BE IT RESOLVED that the City Council of Monticello, Iowa does hereby approve the Plat of Survey for Parcel 2026-27.

IN TESTIMONY WHEREOF, I have hereunto subscribed my name and caused the Great Seal of the City of Monticello, Iowa to be affixed hereto.
Done this 6th day of April, 2026.

Jake Ellwood, Mayor

Attest:

Sally Hinrichsen, City Clerk/Treasurer

| Index Legend |
|--|
| Location: Parcel 2026-27, City of Monticello |
| Requestor: JAMES C. BOWERS |
| Proprietor: JAMES C. BOWERS |
| Surveyor: MICHAEL J. WEBER |
| Surveyor Company: Weber Surveying, LLC |
| & Return To: 26789 46th AVE, Bernard, IA 52032, mjweber1@bernardtel.com |

PLAT of SURVEY of PARCEL 2026-27 in the City of Monticello, Iowa

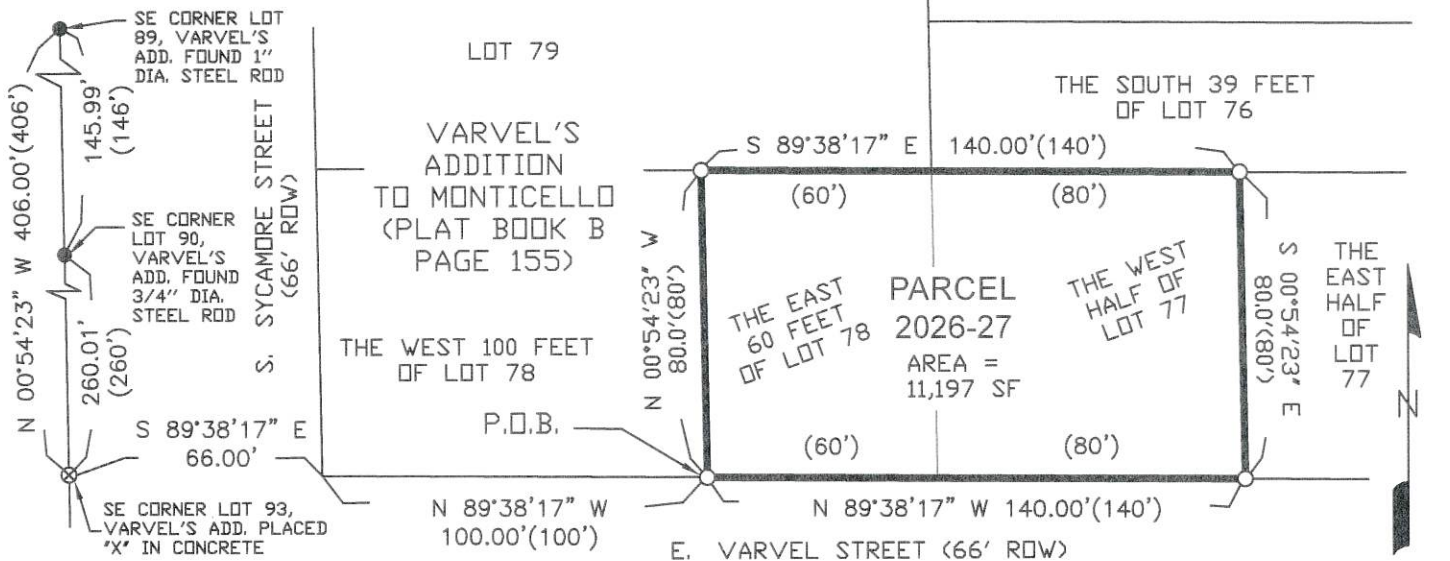

NOTES:

1. ALL MEASUREMENTS ARE IN FEET AND DECIMALS THEREOF.
2. THIS PLAT IS SUBJECT TO RIGHT OF WAY AND EASEMENTS OF RECORD AND NOT OF RECORD.

- PLACED 5/8" DIA. STEEL REROD W/ORANGE PLASTIC CAP MARKED "WEBER PLS 15084"
- FOUND MONUMENT DESCRIPTION NOTED

- SURVEYED LINE
- - - EXISTING LOT LINE
- P.O.B. POINT OF BEGINNING
- < > RECORDED DIMENSION
- ROW RIGHT OF WAY

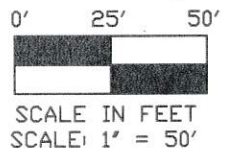

DESCRIPTION: Parcel 2026-27 being a consolidation of the West Half of Lot 77 and the East 60 feet of Lot 78 all in Varvel's Addition to Monticello, Iowa, as shown in Plat Book B page 155 of the Jones County Recorder's Office, more particularly described as follows: Commencing at the SW corner of the East 60 feet of Lot 78 of the said Varvel's Addition being the point of beginning; thence N 00°54'23" W (assumed bearing), 80.00' to the NW corner of the said 60 feet of Lot 78; thence S 89°38'17" E, 140.00' along the North line of said Lot 78 and the North line of said Lot 77 to the NE corner of the West Half of said Lot 77; thence S 00°54'23" E, 80.00' to the SE corner of the West Half of said Lot 77; thence N 89°38'17" W, 140.00' along the South line of said Lot 77 and the South line of said Lot 78 to the point of beginning, containing 11,197 square feet and subject to easements of record and not of record.

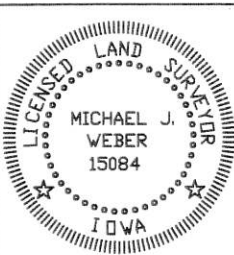

I HEREBY CERTIFY THAT THIS LAND SURVEYING DOCUMENT WAS PREPARED AND THE RELATED SURVEY WORK WAS PERFORMED BY ME OR UNDER MY DIRECT PERSONAL SUPERVISION AND THAT I AM A DULY LICENSED LAND SURVEYOR UNDER THE LAWS OF THE STATE OF IOWA.

Michael J. Weber March 17, 2026
 MICHAEL J. WEBER (DATE)
 LICENSE NUMBER 15084
 MY LICENSE RENEWAL DATE IS DECEMBER 31, 2027

SHEETS COVERED BY THIS SEAL: Sheet 1

WEBER SURVEYING, LLC
 26789 46TH AVE
 BERNARD, IA 52032
 PH: (563) 590-4993
 mjweber1@bernardtel.com

DRAWN BY: MJW
 SURVEY DATE: 3/16/26
 DWG: 26029

SHEET 1 OF 1

City Council Meeting
Prep. Date: 4/1/2026
Preparer: Sally Hinrichsen



Agenda Item: # 22-32
Agenda Date: 4/6/2026

Communication Page

Agenda Items Description: Reports

Type of Action Requested: Motion; Resolution; Ordinance; **Reports**; Public Hearing; Closed Session

Attachments & Enclosures:

| |
|--|
| |
| |
| |

Fiscal Impact:

| | |
|-------------------|--|
| Budget Line Item: | |
| Budget Summary: | |
| Expenditure: | |
| Revenue: | |

Reports / Potential Actions:

- 22. Mayor
- 23. City Engineer
- 24. City Administrator
- 25. Police Chief
- 26. Water/Wastewater Superintendent
- 27. Park and Recreation Director
- 28. Library Director
- 29. Ambulance Director
- 30. City Clerk
- 31. Public Works Director
- 32. Council